

TriAqua



SPLIT MULTIFUNCTIONAL AIR TO WATER HEAT PUMP

(Heating, Cooling and Domestic Hot Water)

(BUILT INSIDE 2 WATER TANKS)



3AQUA-11

3AQUA-14

3AQUA-17

3AQUA-19



MANUAL OF INSTALLATION,
OPERATION AND MAINTENANCE

TABLE OF CONTENTS

1. INTRODUCTION	7
2. DESCRIPTION OF THE UNIT.....	8-10
3. TECHNICAL DATA	11
4. ELECTRICAL DATA.....	12
5. OPERATING LIMITS	13
6. DIMENSIONS.....	14-15
7. SERVICE SPACE	16
8. AIR CONDITIONING WATER PUMP.....	17
9. INSTALLATION	18
9.1 Safety Considerations	18
9.2. Location of the Units.....	19
9.3. Hydraulic Connections	20-24
9.4. Electrical Connections.....	25-27
9.5. Refrigerant Connections.....	28
9.6. Applying a vacuum to the Refrigerant installation	29
9.7. Re-charging Refrigerant (R-410A)	29-30
9.8. Pressure Measurements.....	30
10. START-UP	31
10.1. Checks Prior to Start-up.....	31
10.2. Verification of the Electric Power Supply.....	31
10.3. Temperature Selection.....	31
10.4. Operating in DHW Mode.....	32
10.5. Operating in Air Conditioning Mode	32

11. CONTROL PANEL.....	33
11.1. Pressure Indicator	33
11.2. Electronic Controller.....	33
11.3. Display.....	34
12. OPERATING THE UNIT	35
12.1. Starting and Stopping the Unit.....	35
12.2. Selecting the Operating Mode.....	35
12.3. Signaling of the Operating Mode.....	35
12.4. Display and Modification of Temperatures	36-37
12.5. Clock and Timer.....	37-40
13. ALARMS.....	41
14. MAINTENANCE.....	42-43

1. INTRODUCTION

The unit that you have acquired has undergone strict quality control before leaving the factory. Do not attempt to manipulate the unit or subject it to working conditions that are not specified in this manual, given that you could lose any type of warranty over the same. Repairs or maintenance must always be entrusted to an official technical assistance service.

The installer company is responsible for performing the installation according to the characteristics of the project while complying with regulations in force.

This equipment must be installed only by a duly qualified professional. The manufacturer declines all liability for any eventual, direct and/or indirect damages caused by improper installation.

When the unit is received, it must be checked to verify that it is in perfect condition. If it is not, you must file a claim in writing with the carrier.

Very important!

Before installing the equipment, this manual must be carefully read, and the instructions and observations included herein must be followed.

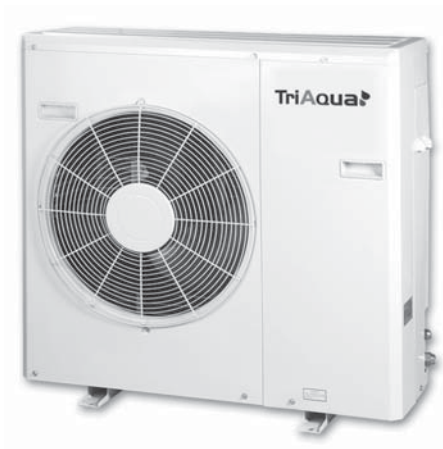

2. DESCRIPTION OF UNIT

Indoor Unit (all models)

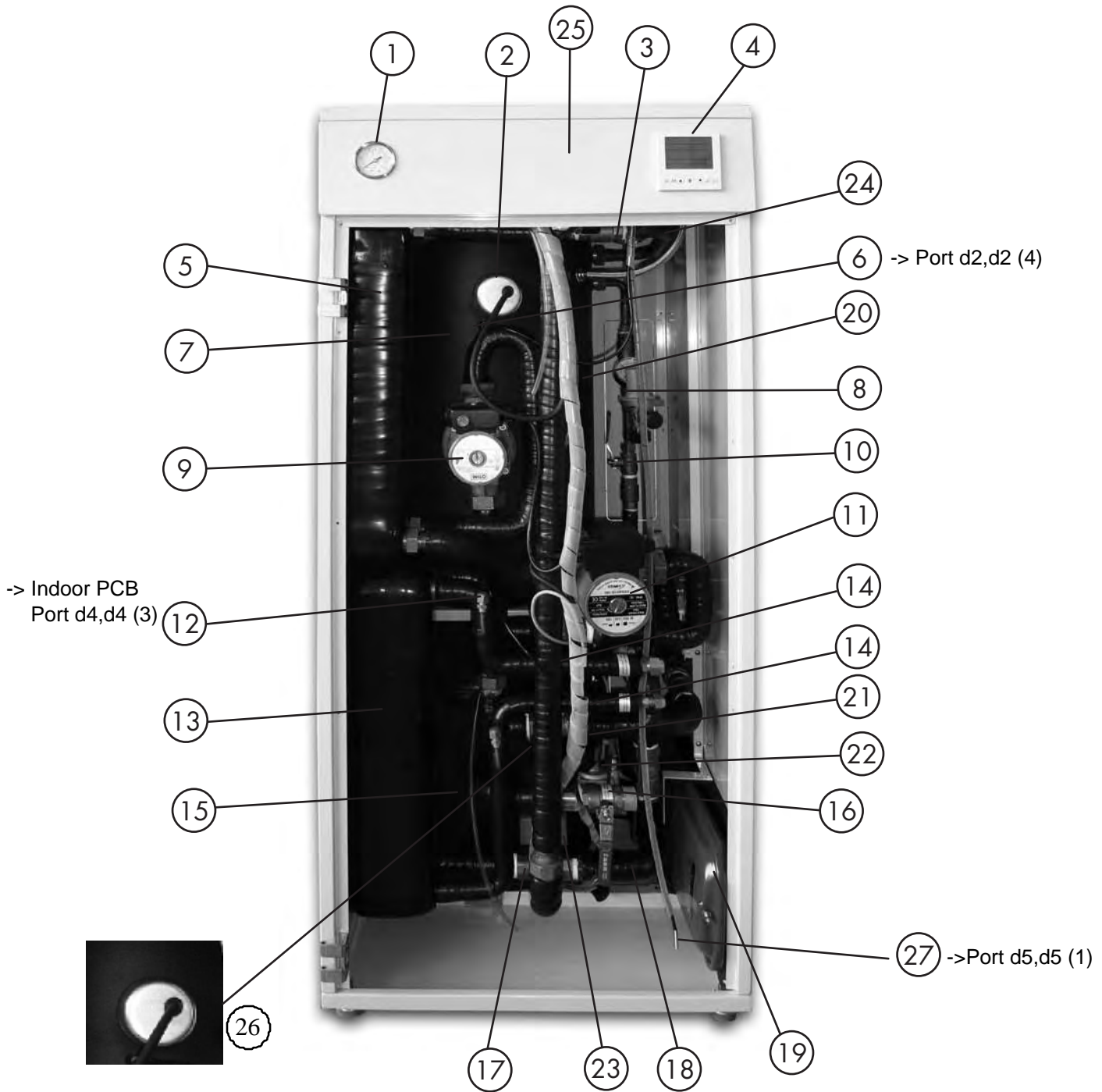

1. Air conditioning water pressure gauge
2. Electric heater 2kW with thermostat for DHW
3. Check Valve $\frac{3}{4}$ " for DHW
4. LCD controller
5. Heat exchanger for DHW
6. DHW temperature sensor -> d2,d2 (4)
7. DHW accumulation water tank
8. Check Valve $\frac{1}{2}$ " for DHW
9. DHW water pump (secondary)
10. Check Valve $\frac{1}{2}$ " for DHW
11. DHW water pump (primary)
12. Air Conditioning Water inlet temperature sensor -> d4,d4 (3)
13. Air conditioning Heat exchanger
14. Air conditioning water shut off valve 1"

15. Air conditioning water tank
16. 1-way electric valve
17. 3-way electric valve
18. Air-conditioning water outlet sensor -> d3,d3 (2)
19. Air conditioning expansion tank
20. DHW safety valve
21. air conditioning control safety valve
22. 1-way electric valve
23. 3-way electrical valve
24. DHW expansion tank
25. Electric control box
26. Electric heater 3x2kW with thermostat for A/C
(Only available for T,D series)

27. Solar water tank sensor (For solar Application 1, Fuzzy logic control)

2. DESCRIPTION OF THE UNIT

11E Outdoor Unit

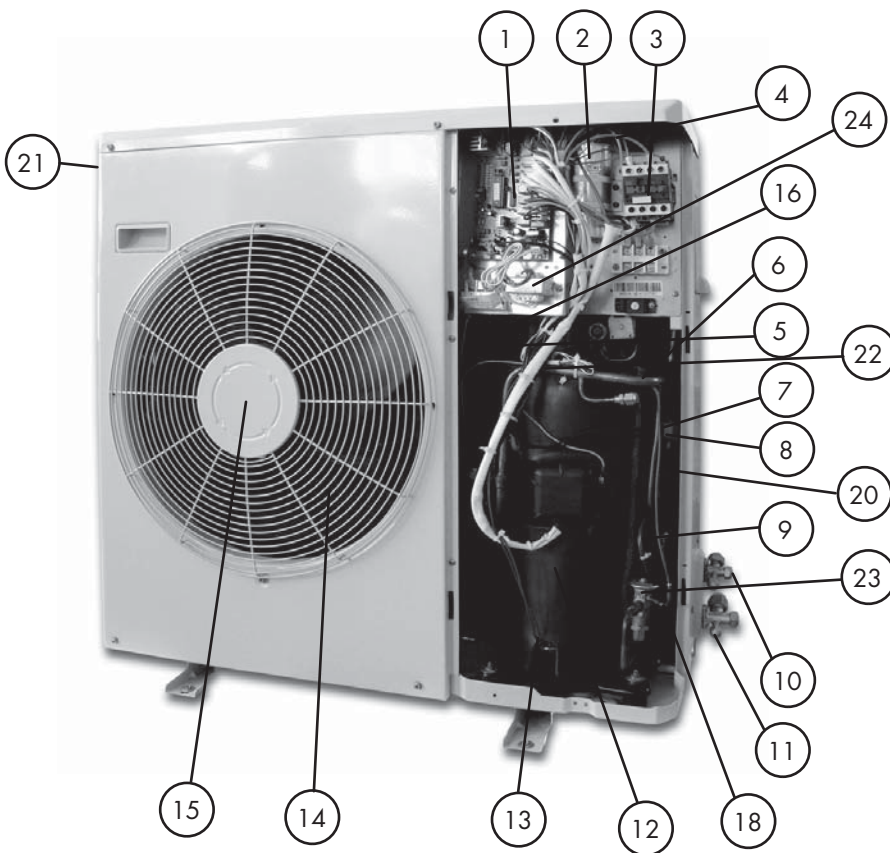

1. Outdoor electronics board
2. Compressor condenser
3. Compressor contactor
4. Fan motor condenser
5. Low pressure pressurestat
6. 4-way valve
7. Injection valve
8. Injection pressurestat (high pressure)
9. High pressure pressurestat
10. Liquid service valve
11. Gas service valve
12. Compressor
13. Compressor crankcase heater
14. Outdoor fan
15. Outdoor fan motor
16. Intake accumulator
17. Compressor start condenser
18. Liquid separator
19. Compressor starter
20. Defrost probe
21. Outdoor air temperature probe
22. Discharge probe
23. Expansion system
24. Transformer

14E Outdoor Unit

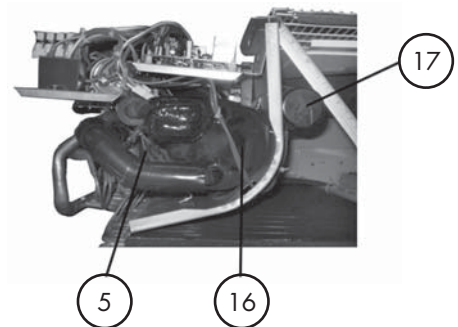
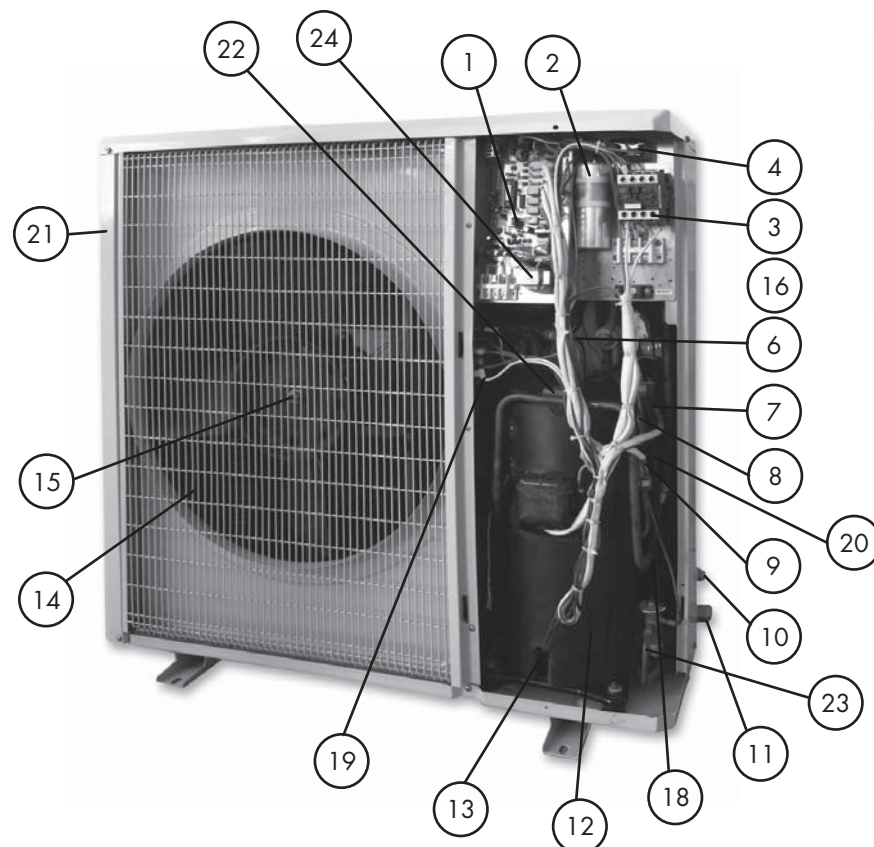

2. DESCRIPTION OF THE UNIT

Outdoor Unit 3AQUA-17E

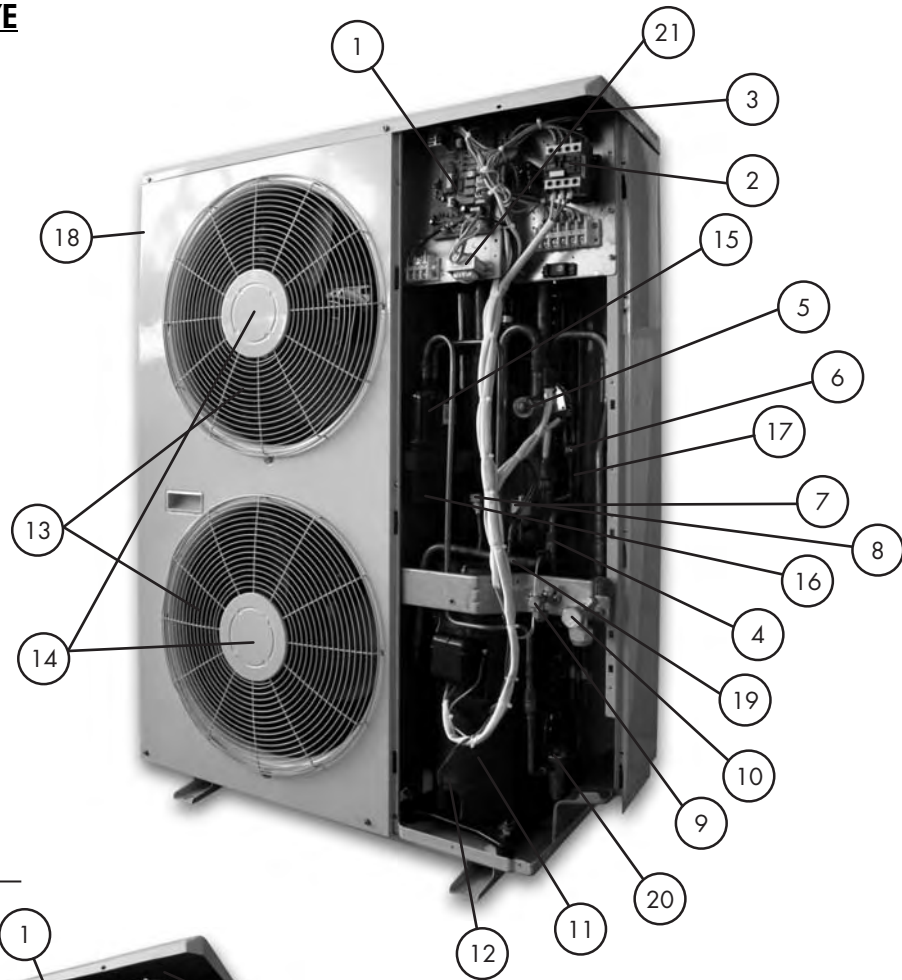

Outdoor Unit 3AQUA-19E

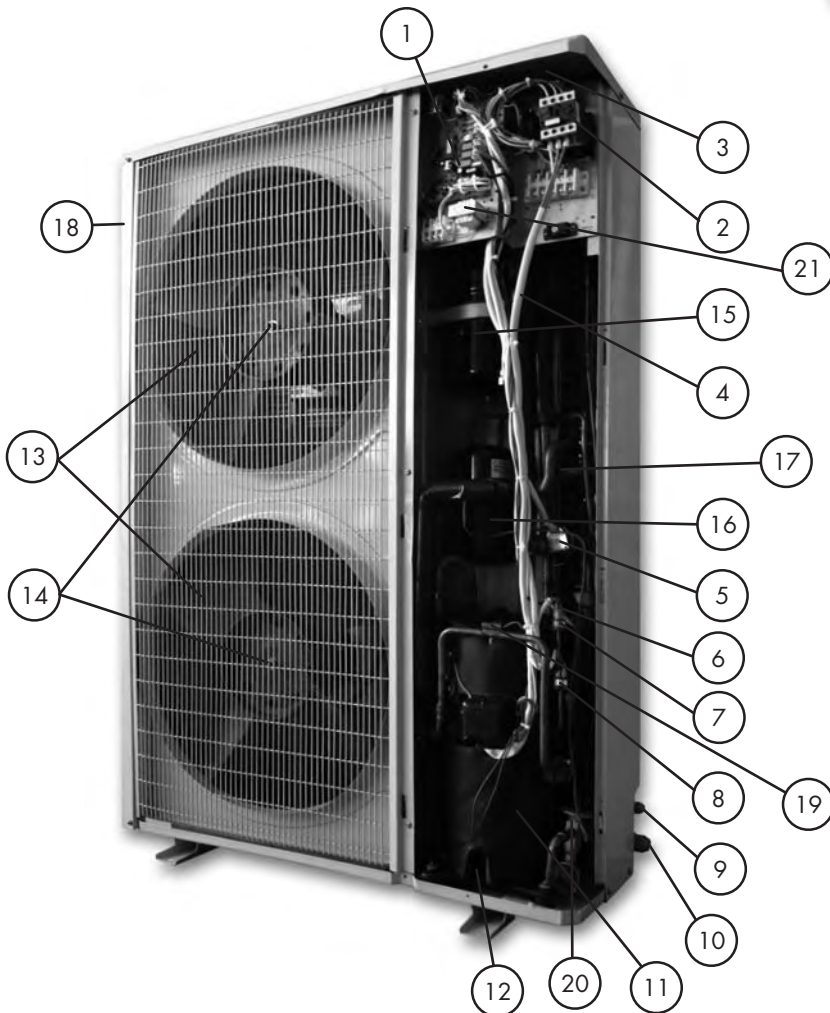

1. Electronic board outside
2. Compressor Contactor
3. Condenser fan motor
4. Low Pressure switch
5. 4-way valve + coil
6. Injection valve +coil
7. Injection pressure (high) switch
8. High pressure
9. Liquid service valve
10. Gas service valve
11. Compressor
12. Compressor crankcase
13. Outdoor fan
14. Outdoor Fan Motor
15. Suction accumulator
16. Liquid separator
17. Defrost sensor
18. Outside air temperature sensor
19. Discharge tube
20. Thermal expansion valve
21. Transformer

3. TECHNICAL DATA

TÉCNICAL CHARACTERS			3AQUA-11	3AQUA-14	3AQUA-17	3AQUA-19
Heating	Capacity Nominal	KW	10,30	14,20	16.50	19,20
	Consumption Nominal	KW	2,45	3,45	3.67	4,55
	COP	W/W	4,20	4,12	4.5	4,22
Cooling	Capacity Nominal	KW	10,60	14,50	17.10	19,50
	Consumption Nominal	KW	3,21	4,46	4.82	6,10
	EER	W/W	3,3	3,25	3.55	3,20
D.H.W	Capacity Nominal	KW	9,56	12,90	15,80	17,75
	Consumption Nominal	KW	2,45	3,49	4,05	4,57
	COP	W/W	3,90	3,7	3,90	3,88
Alimentación eléctrica		V/Ph/Hz	230/1/50		400/3/50	
Gas line		Inch	5/8"	3/4"		
Liquid line		Inch	3/8"			
Compressor type			Scroll			
Refrigerant type			R-410A			
Refrigerant charging volume		Kg.	2.40	3.20	4.50	4.70
Volumen acumulatfor air conditioning		Litros	50			
Volumen acumulator D.H.W		Litros	90			
Pressure max climate		Bar	3			
Air condition expansion tank volume		Litros	6			
Max Pressure D.H.W		Bar	7			
DHW expansion tank volume		Litros	2			
Air conditioning input/output		mm	28			
Tap water input		mm	15			
DHW water output		mm	15			
DHW/Air conditioning safety valve		mm	15			
Drain valve		mm	15			
Dimension (HeightxWeightxLength)	Indoor unit	mm	1.360 x 590 x 590			
	Outdoor unit	mm	860x870x325	960x970x345	1260x970x345	1460x970x345
Packed Dimensions (HeightxWeightxLength)	Indoor unit	mm	1.470 x 650 x 650			
	Outdoor unit	mm	980x985x415	1080x1085x465	1390x1085x465	1590x1085x465
Net weight	Indoor unit	Kg.	125	128	132	135
	Outdoor unit	Kg.	75	100	120	130
Packed weight	Indoor unit r	Kg.	140	143	147	150
	Outdoor unit	Kg.	85	112	135	147
Noise level	Indoor unit	dB(A)	28			
	Outdoor unit	dB(A)	48	49	51	52
Max pipe length		m	50			
Max height difference		m	30			
Min water flow		L/S	0.5	0.7	0.9	1

NOTES:

* Capacities and consumption based on the following conditions:

- Heating: Temperature inlet / outlet water 30/35 ° C. Temperature wet / dry air 6 ° C / 7 ° C.
- Cooling: Temperature inlet / outlet water 23/18 ° C. Dry air temperature 35 ° C.
- DHW: Outlet water temperature 45 ° C. Temperature wet / dry air 6 ° C / 7 ° C.

* Refrigerant charge is valid for a line length of 5 meters.

* The net weight of the indoor unit does not include the weight of accumulated water in it.

* The sound pressure level is measured at 5 meters from the unit.

4. ELECTRICS DATA

Electrical consumption

TECNICAL CHARACTERS		3AQUA-11	3AQUA-14	3AQUA-17	3AQUA-19
Operating Voltage	V/Ph/Hz	230/1/50	230/1/50	400/3/50	400/3/50
Voltage mín	V	205	205	360	360
Voltage max	V	253	253	440	440
Consumo					
Nominal Cooling *	kW	3,30	4,50	5,20	5,60
	A	15,80	21,20	8,50	9,20
Nominal Heating **	kW	2,55	3,55	4,15	4,70
	A	12,20	16,80	6,80	7,75
Nominal Domestic hot water ***	kW	3,25	4,30	5,10	5,70
	A	15,50	20,40	8,40	9,40
Max Cooling	kW	3,85	5,55	6,80	7,00
	A	18,30	26,30	11,20	11,50
Max Heating	kW	3,85	5,30	6,20	7,00
	A	18,30	25,10	10,20	11,50
Max D.H.W..	kW	4,15	5,40	6,40	7,20
	A	19,80	25,50	10,50	11,80

NOTE:

* Temp. Input / Output water 23/18 ° C. Outdoor air temp. dry bulb 35 ° C.

** Temp. Input / Output water 30/35 ° C. Wet / dry air temp 6 ° C / 7 ° C.

*** Temp. water outlet 45 ° C. Wet / dry air temp 6 ° C / 7 ° C.

Max current consumption used for Triaqua

Super model	Indoor unit without a/c electric heater	Indoor unit with electric heater	Outdoor unit	Max Current	
				Seperate power supply for indoor and outdoor unit	Indoor power supply from outdoor unit
3AQUA-11	15A	25A	20.0A	25A	45A
3AQUA-14	15A	35A	25.5A	35A	60.5A
3AQUA-17	15A	35A	10.5A	35A	45.5A
3AQUA-19	15A	35A	11.8A	35A	46.8A

The above current value can also be used to choose correct power cord. It is important for safety.

*Note: if you need very low current, you can choose our full 3 phase models.

5. OPERATING LIMITS

Operating Limits Cooling Mode

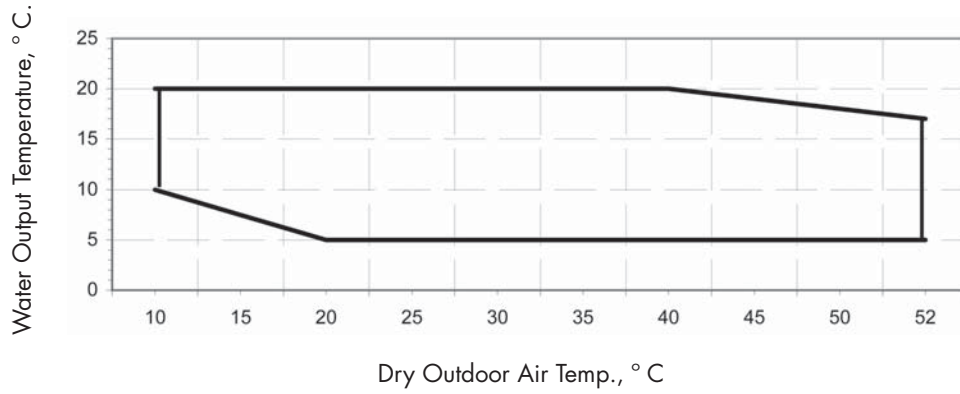

Operating Limits Heating Mode

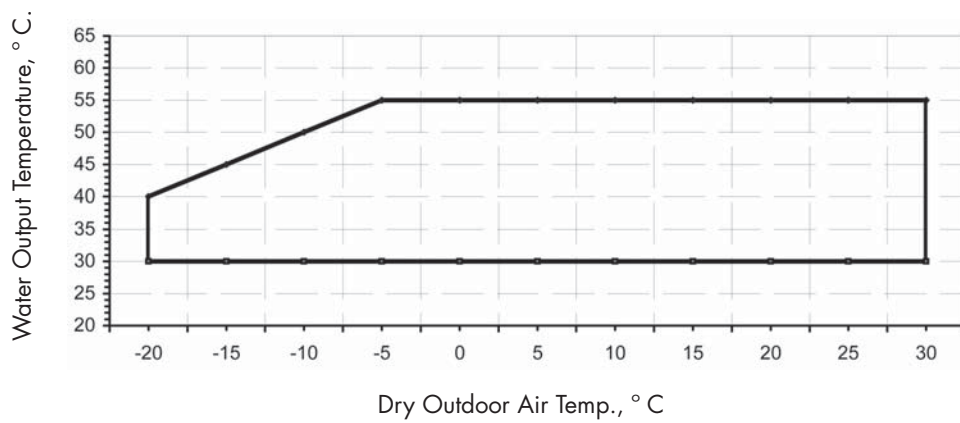

Operating Limits DHW Mode

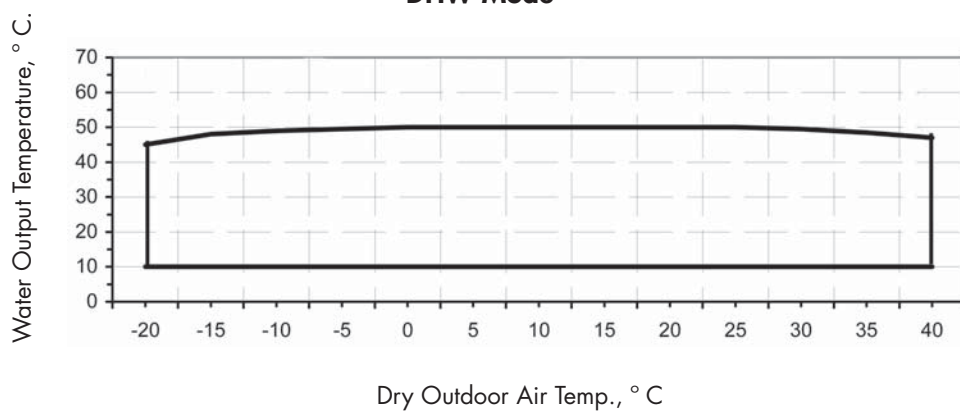

6. DIMENSIONS

Indoor Unit (all models)

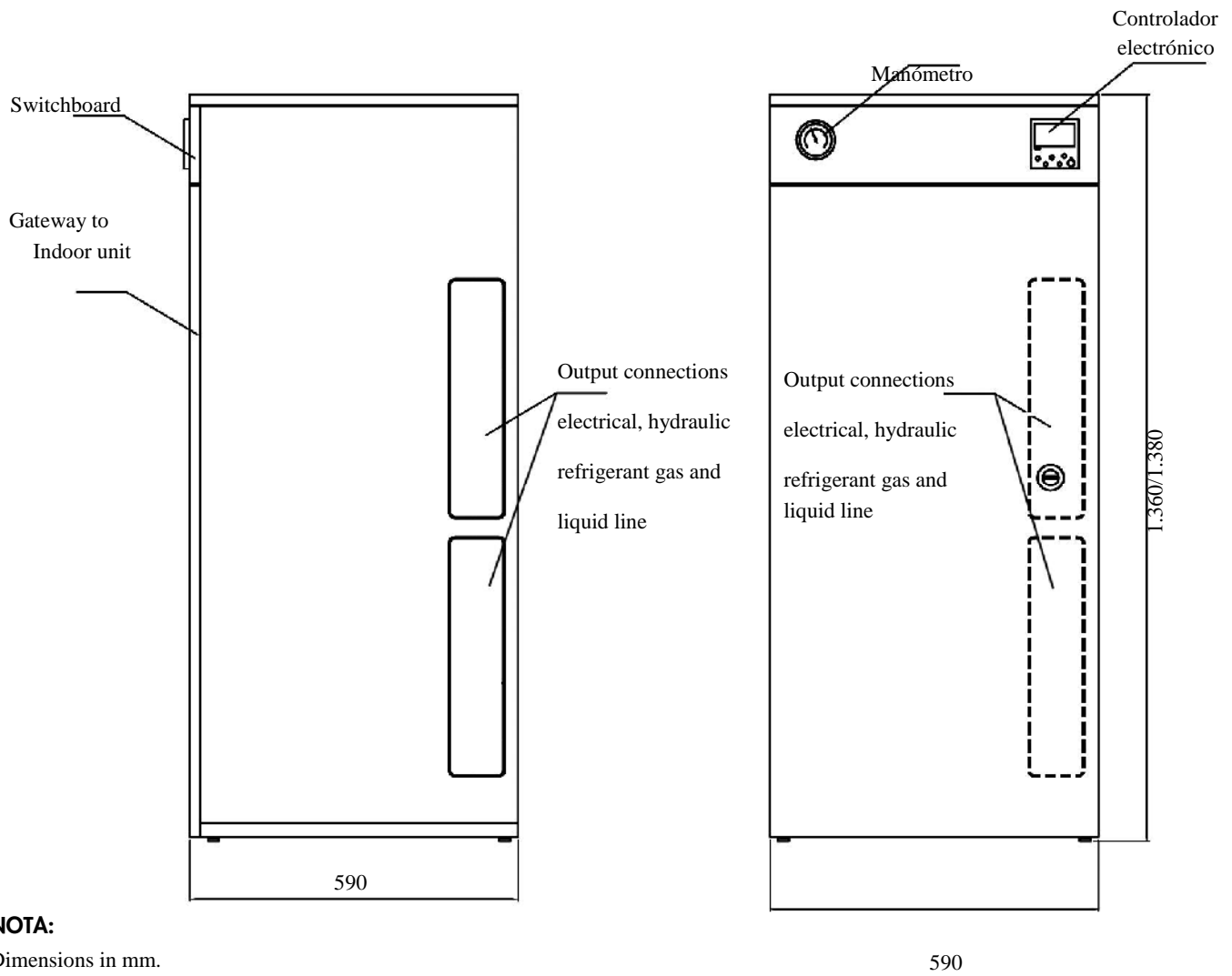

NOTA:

Dimensions in mm.

Outdoor unit 3AQUA-11E/3AQUA-14E

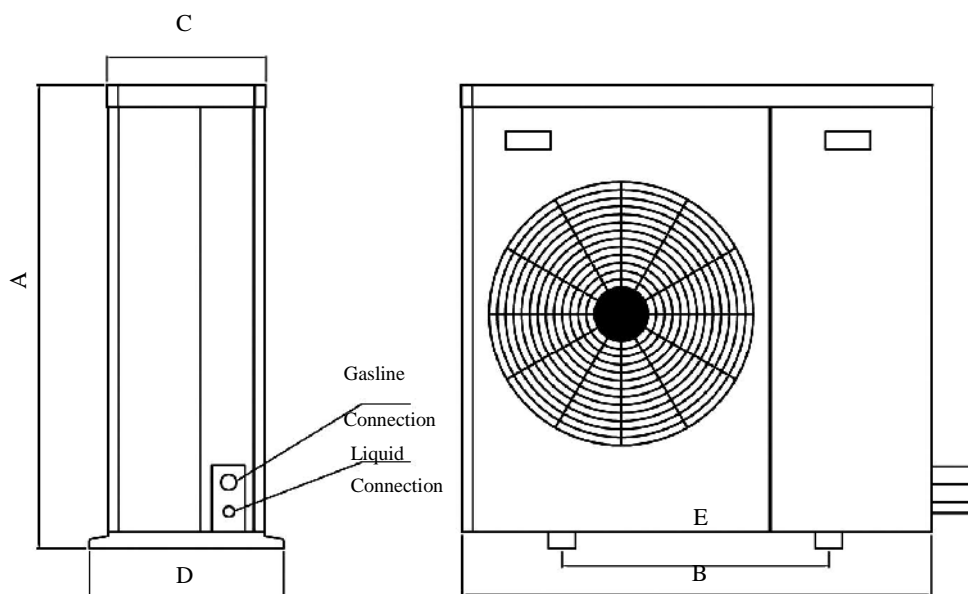

6. DIMENSIONES

Outdoor unit 3AQUA-17/19E

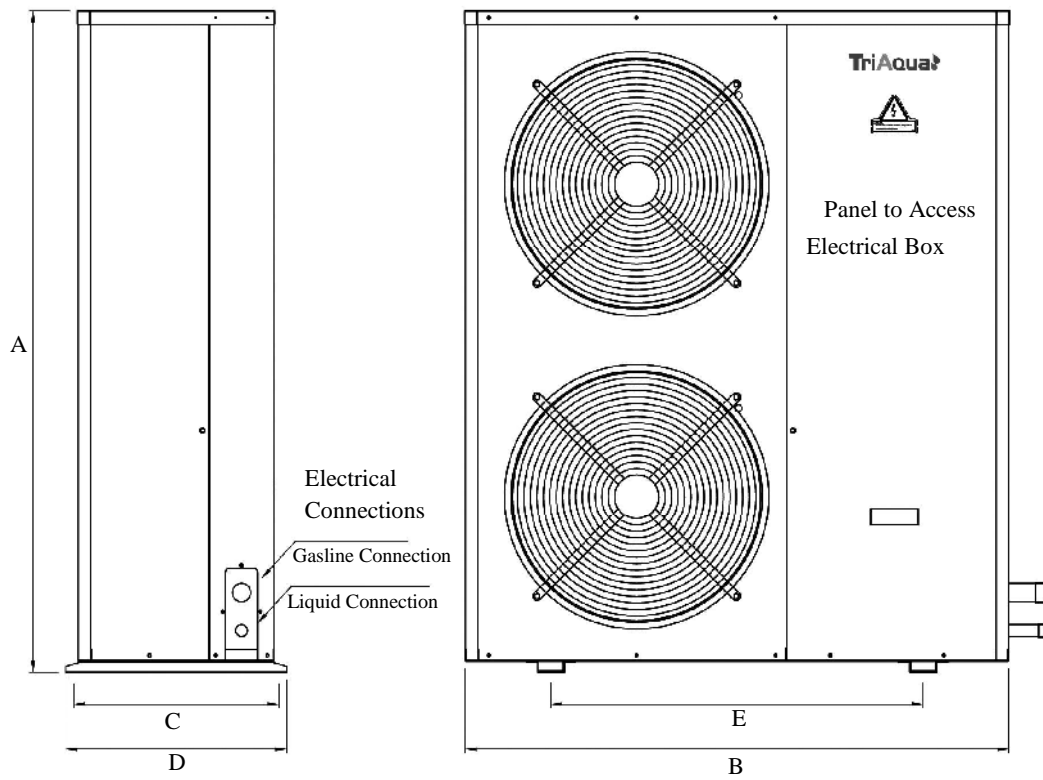

MODEL	DIMENSIONS (in mm)				
	A	B	C	D	E
3AQUA -11E	860	870	325	365	500
3AQUA -14E	960	970	345	415	640
3AQUA -17E	1.260	970	345	415	640
3AQUA -19E	1.460	970	345	415	640

7. SERVICE SPACE

The minimum required space for performing service and maintenance tasks on the units is indicated below.

Indoor Unit (all models)

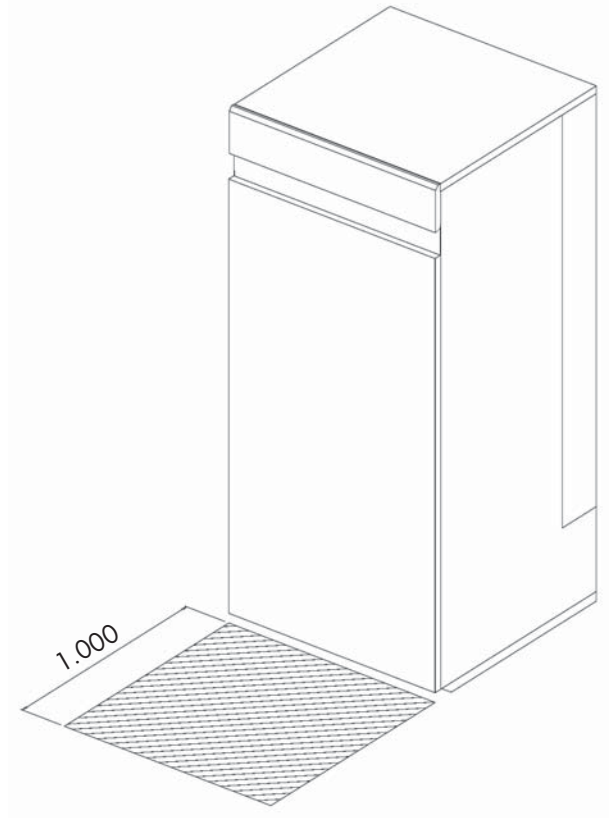

Outdoor Unit (all models)

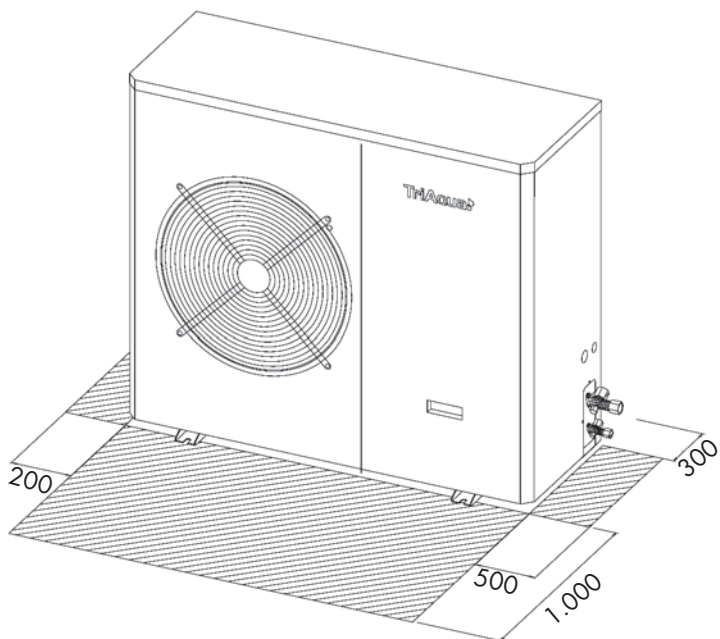

NOTE:
Dimensions in mm.

8. AIR CONDITIONING WATER PUMP

AIR CONDITIONING WATER PUMP

The selection of cooling water pump to be mounted by the installer out of the unit should take based on the flow rates of cooling and heating, internal drop unit (see graph) and the drop of the facility.

Calculation of nominal water flow:

$$Q \text{ water (l / h)} = \text{Cooling Capacity} * 0.86 \text{ (Kcal / h)} / \Delta T \text{ (}^\circ \text{C)}$$

$$\text{As } \Delta T = (\text{T first exit water temp} - \text{water return Temp}) \text{ } \Delta T = 5^\circ \text{C}$$

Example: Model 3AQUA-15

$$Q \text{ water} = (16,300 \text{ W} * 0.86) \text{ Kcal / h} / 5^\circ \text{C} = 2800 \text{ l / h}$$

IMPORTANT: The temperature difference in air conditioning heat exchanger should be 5 ° C approx. A high temperature difference can cause a malfunction of the unit and even irreparable damage to it.

Triaqua air conditioning Pressure Drop in Hydraulic Circuit

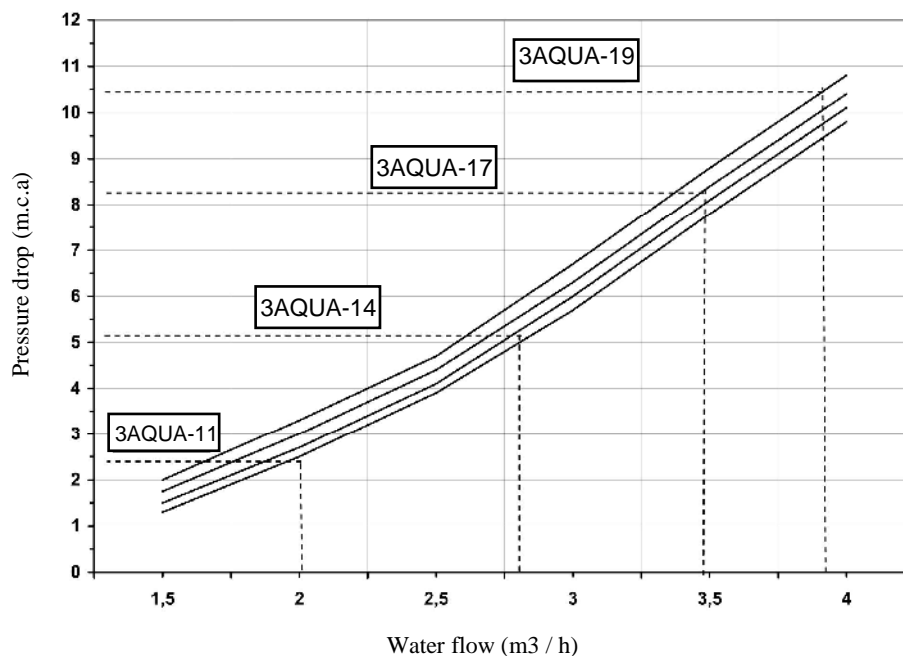

1 m.c.a = 10 Kpa

The graph indicates the pressure drop of cooling water circuit of the unit (components inside the unit).

9. INSTALLATION

9.1 SAFETY CONSIDERATIONS

A series of recommendations to follow for correct installation of the unit are included below.

The installation, repair and maintenance of these units must be performed with caution because of the presence of electrical and electronic components and because of the pressure system of the refrigerant circuit. Only trained and qualified personnel should perform installation, adjustment and maintenance operations on the unit.

The manufacturer declines all liability in the event of negligence or the failure to follow the safety rules described below:

- Work under completely safe conditions, free from obstacles and in a clean environment.
- Respect legislation in force.
- Before starting up the unit, confirm that both the unit and its components are in perfect condition.
- Use safety goggles and gloves when working. Use a fireproof blanket during welding operations.
- Position units on firm ground that supports the load weight and that allows maintenance to subsequently be performed correctly on the same.
- Use the specified cables, and make the correct connection to terminals.
- Provide an independent power supply connection for the unit.
- Verify that the supply voltage corresponds to the voltage on the specifications plate.
- Make the corresponding earth connection.
- Safely perform the installation work of the hydraulic and drainage lines according to the instructions in this manual and according to legislation in force.
- When the unit is operating, some parts of the refrigerant circuit (compressor and discharge line) can reach temperatures exceeding 70° C. Be especially careful when accessing the interior of the unit.
- The unit can work in "normal" environments of residential, commercial or light-industry installations. The unit cannot be installed in an explosive atmosphere or an atmosphere that is aggressive to the unit's components. For special applications, the manufacturer must be consulted.

Very important!

Before beginning any installation or repair operations on the unit, turn off the main electric power supply switch. An electric shock can cause personal injury.

9. INSTALLATION

9.2 LOCATION OF THE UNITS

Inspect the units when they are received to verify that no damage has occurred during transport. If a unit is damaged, a claim must be submitted immediately to the company that made the delivery.

Location of the Indoor Unit

The indoor unit is designed to be installed inside a home. Therefore, the indoor unit has the same measurements at the base as those of a common electrical appliance. The height can also be adjusted using small, adjustable legs.

When the indoor unit is installed, the area around the access door must be left free. The spaces described in section 7 (Service Space) must also be left free.

Location of the Outdoor Unit

The outdoor unit must be installed with an orientation that is suited to the weather characteristics of the region where it is installed. In case of doubt, consult the manufacturer.

It must be installed so that air circulates freely, thereby preventing the effects of re-circulations, which can reduce the unit's performance.

When the outdoor unit is installed, the area around the front of the unit must be left free. The spaces described in section 7 (Service Space) must also be left free.

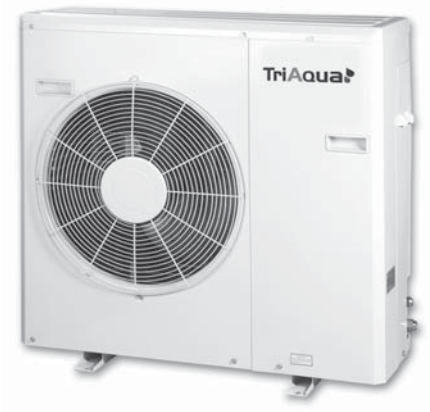

9. INSTALLATION

9.3 HYDRAULIC CONNECTIONS

All the hydraulic connections are identified, as it can be seen in Figures 1 and 2:

Figure 1

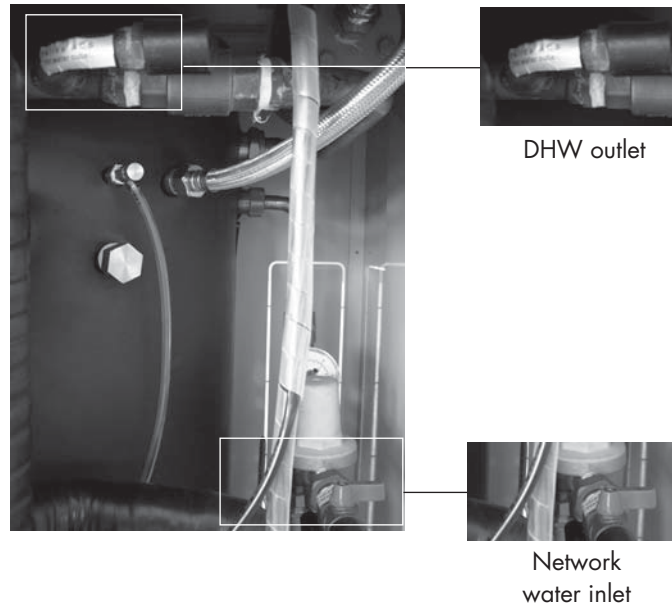
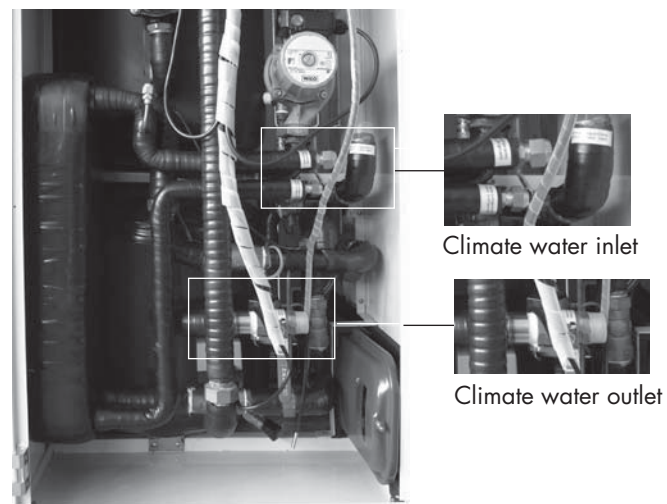

Figure 2



The unit is equipped with flexible hoses to facilitate the hydraulic connections of the air conditioning circuit (Figure 3).

Figure 3



9. INSTALLATION

The common intake must be led from the safety valves of the two tanks to the drain (Figure 4).

Figure 4

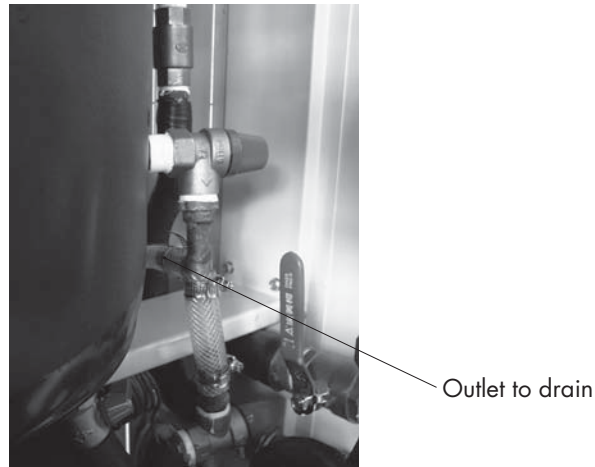

Air Conditioning Hydraulic Circuit

- Water pump

The operation of the closed air conditioning circuit means that water carries the heating or cooling energy from the Triaqua unit to the secondary unit of the installation. This forced circulation is performed by the water pump.

This water pump must be installed by the installer and must be calculated to meet the required water flow rate and to be able to overcome the head loss (installation + machine). See section 8.

For its electrical condition, see section 9.4 (Electrical Connections).

IMPORTANT: A pump that is too small could cause inadequate operation or even irreparable damage.

- Water Flow switch

It is essential to ensure that there is a minimum flow of water in the air conditioning circuit. It is therefore necessary to install a flow switch to protect the machine.

The indoor unit comes prepared for the electrical condition of the flow switch (WT-WT connections) (terminals 17 and 18).

Figure 5

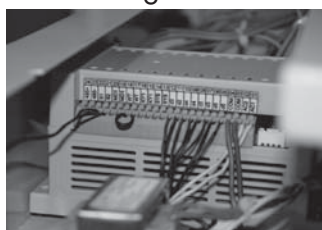

The bridge between those terminals must be removed, and the flow switch must be connected to them.

IMPORTANT: Insufficient water could cause irreparable damage to the unit.

9. INSTALLATION

- Differential pressure valve

In order to ensure that water always returns to the unit on the air conditioning circuit, a differential pressure valve must be installed. The differential pressure switch guarantees the required minimum flow rate for proper operation of the heat pump when the thermostatic valves close, and it limits the differential pressure of the installation.

IMPORTANT: If water does not return to the unit, it could cause irreparable damage to the unit.

Filling the hydraulic circuits and checking pressures

Very important!

In order to fill the hydraulic circuits, proceed in the order indicated below.

1. Filling the DHW secondary circuit. (DHW plate exchanger - DHW tank).

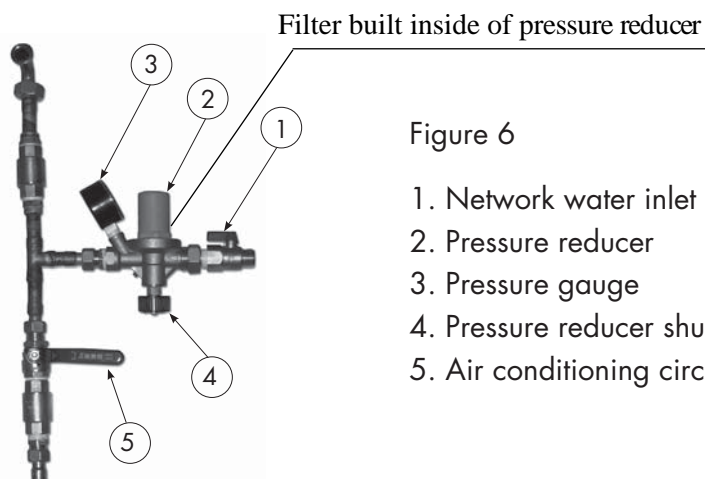
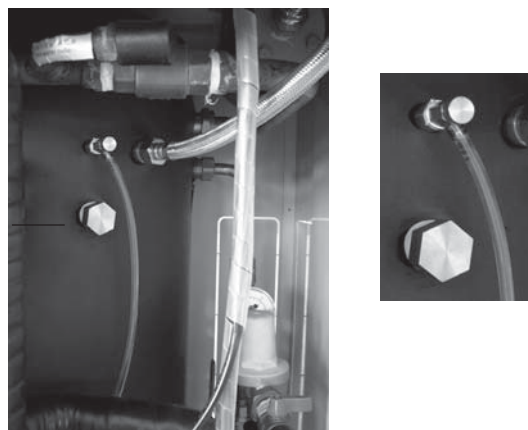

Figure 6

1. Network water inlet valve
2. Pressure reducer
3. Pressure gauge
4. Pressure reducer shut-off valve
5. Air conditioning circuit fill valve

- Open the water inlet valve of the unit's network (see Figure 6)
- Open the air bleed of the DHW tank (Figure 7). Close this air bleed when air stops coming out and water does.
- Open any DHW consumption point to bleed air from the installation.
- The indoor unit incorporates a pressure regulator valve (factory-rated to 2.5 bar). If necessary, adjust the water inlet pressure to the unit (normally 2.5-3 bar).
- Check that the DHW pump rotates in the correct direction by accessing the shaft of the same through the maintenance screw.

Figure 7



9. INSTALLATION

2. Filling of the air conditioning circuit (air conditioning plate exchanger - air conditioning buffer tank).

- Be sure that the circuit to be climatized (radiating floor, fan-coil, etc.) has previously been filled and bled.
- Keep all water inlet and outlet shut-off valves closed (Figure 9).
- With the water inlet valve of the unit's network open (1), Figure 6, open the manual fill valve of the air conditioning circuit (Figure 8).
- Open the manual bleed located at the top of the air conditioning tank, and keep it open until all the air has been eliminated from the circuit (Figure 10).

Figure 8

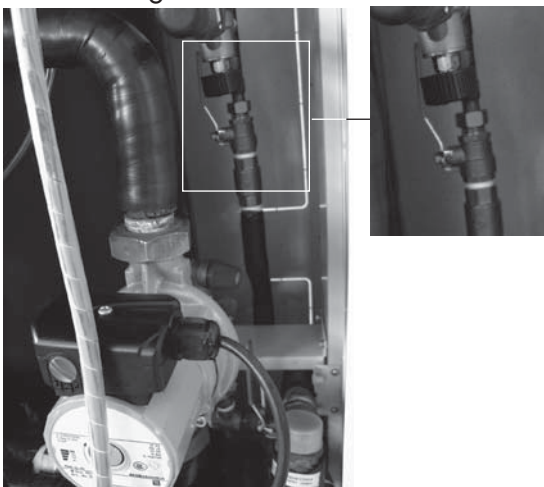

Inlet
shut-off
valve

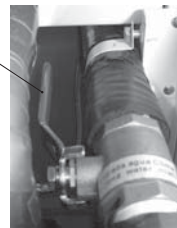
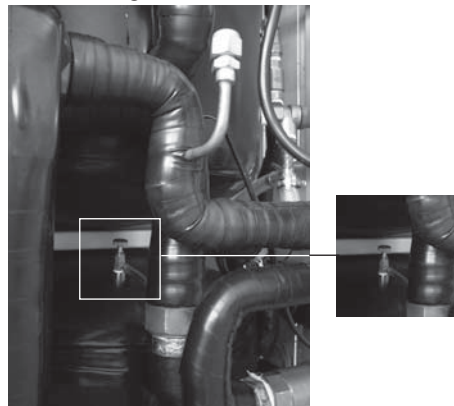

Figure 9



Outlet
shut-off
valve

Figure 10



- Check the two D.H.W. water pumps are turning correctly by checking its axis working by opening the maintenance screw in the middle of the water pump. Rotate the maintenance screw for several times with a screw driver.



maintenance screw

Figure 5.4

9. INSTALLATION

- Once the air has been bled from the unit, close the air conditioning fill valve (Figure 8), and use the pressure gauge installed on the unit's control panel to check that the pressure of said circuit is around 1.5 bar.

3. Filling of the primary DHW circuit (DHW plate exchanger - air conditioning plate exchanger)

- Open the air bleed of the primary DHW circuit (Figure 11).

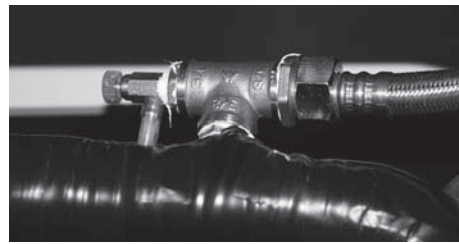

- Connect the electric power supply to the indoor unit, WITHOUT TURNING THE UNIT ON, and select the DHW operation.
- The 3-way water valve of the air conditioning circuit activates and begins to fill said primary DHW circuit (hydraulic circuit between the plate exchangers).
- When water comes out through the air bleed of this primary DHW circuit, close the air bleed and disconnect the electric power supply to the indoor unit.
- If it were necessary, fill the air conditioning hydraulic circuit with water. Open the fill valve of said circuit (Figure 8). Keep the pressure around 1.5 bar.
- Open the shut-off valves (inlet and outlet) of the air conditioning circuit (Figure 9)
- Use the pressure gauge installed on the control panel of the indoor unit to check the pressure of the air conditioning hydraulic circuit (normal is 1.5 bar).
- Be sure that the entire installation of the circuit to be air conditioned has water pressure and is completely bled of air. The existence of air in the air conditioning circuit could cause irreparable damage to the unit. It is essential to adequately bleed the air conditioning circuit of the installation. To do so, air bleeds will have been installed at the highest part of the home's circuit in order to suitably eliminate all air in the installation.
- It is advisable to connect the air conditioning pump directly to the network - meaning only the water pump of the air conditioning circuit - for a period of time in order to eliminate any air in said circuit.

Attention!

Do not turn on the unit to operate the water pump. If the unit is turned on while the pump is running to bleed air from the air conditioning water circuit, irreparable damage could be caused to the unit.

9. INSTALLATION

Water filter (air conditioning circuit)

- The unit has a mesh filter (Figure 12) on the air conditioning (return) circuit, and its mission is to retain particles or dirt that could remain in the home's air conditioning circuit.

Figure 12

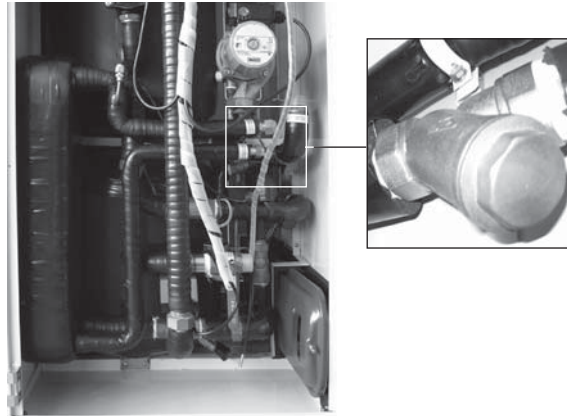

Attention!

Dirt in the installation could cause irreparable damage to the unit.

- After making all the connections and after filling the circuit, and before turning the unit on, it is advisable to turn on the pump of the air conditioning circuit for a period of time in order to retain any particles and impurities that could be in the installation. To do so, the air conditioning pump has to be connected directly to the network.
- Once this operation has been performed, and with the pump stopped, the inlet and outlet shut-off valves of the air conditioning circuit (Figure 9) must be closed, the water must be drained from the air conditioning tank through its drain, and the filter's mesh must be cleaned. Afterwards, the circuit will be filled again.
- In order to be sure that there is no dirt in the circuit, it is advisable to perform this operation as many times as necessary.
- After having checked that the air conditioning circuit is clean, fill it with glycol to approximately 20% of the total volume of the installation.
- It is advisable to make periodic checks, which includes cleaning the filter's mesh, in order to be sure that there is no dirt in the circuit.

Water treatment

It is advisable to install a filtering system (water softener, etc.) to prevent the build-up of lime and other minerals from the water on the pipes or on some components of the unit. This will prevent damage to both the installation and the unit itself.

Likewise, it is advisable to perform periodic maintenance on the installation and unit.

9. INSTALLATION

9.4 ELECTRICAL CONNECTIONS

Before starting any work on the electrical installation, be sure that the main power switch is disconnected.

General recommendations

- The installer must protect the unit's electric power supply line using automatic disconnection devices, a circuit breaker and a residual-current device that are suitable for the installation and in accordance with legislation in force.
- The electric power supply to the unit has to be within a certain voltage range (see the table of electric consumption in section 4).
- Special care must be taken when connecting the earth cable. The earth cable should be somewhat longer than that of the phase cable.

Preliminary operations

On the outdoor unit:

- Remove the access panel to the electrical panel located on the front right of the unit.
- Check that the characteristics of the network match the data indicated on the unit's serial plate.
- Make the electric power supply connection and interconnection between the outdoor and indoor units through the 2 cable seals located on the side of the unit.

Figure 13

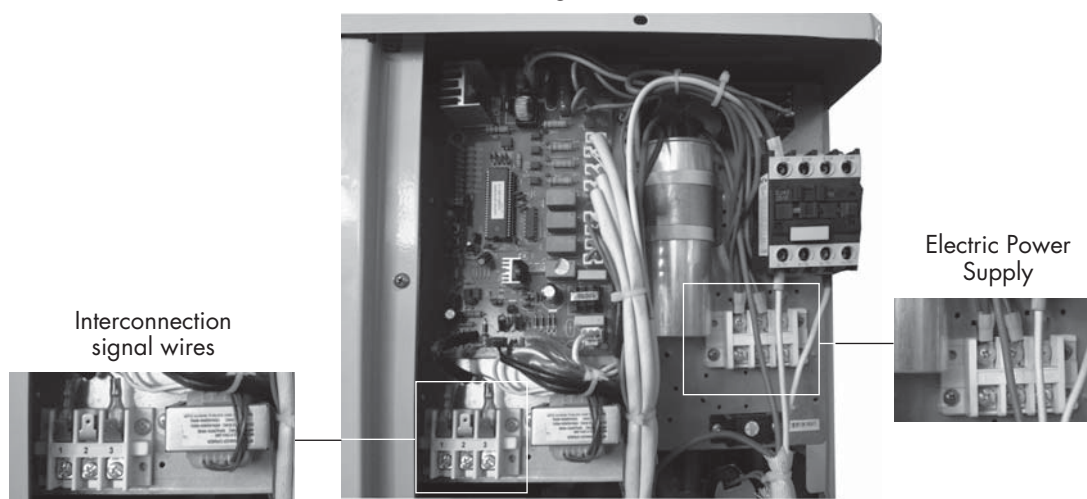

- Be sure that the cross section of the electric power supply cables is suitable for the total consumption of the unit. See the table below.

On the indoor unit:

- Open the front panel by turning the unit's latch.
- Unbolt the control panel from the structure of the unit, and slide it out along the support guides so that you have access to the unit's connection terminal board (Figure 14).

9. INSTALLATION

Figure 9

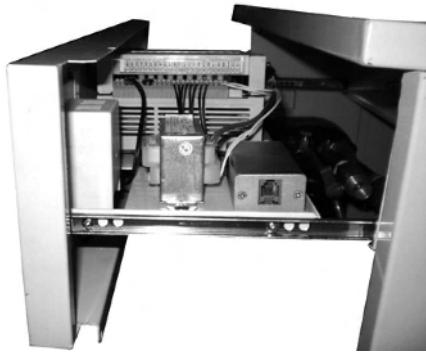

Figure 11

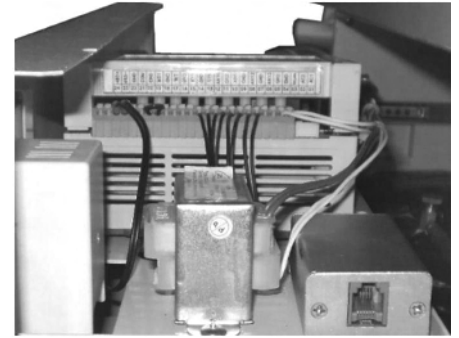
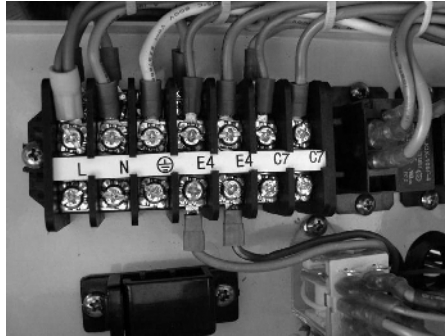

Figure 10



Power supply (connection and interconnection between units)

Before commissioning of the unit must perform the following connections:

- Mains supply (outdoor unit), Figure 8.
- Interconnection between the outer and inner drive, figures 8, 10 and 11.
- Connect the air conditioning water pump, Figure 10.

MODEL	Outdoor Power SUPPLY	Indoor power SUPPLY	COMMUNICATION
3AQUA-11	3 x 4 mm	3 x 4 mm	<u>SIGNAL</u> (no polarity) 2 x 0,5 mm
3AQUA-14	3 x 4 mm	3 x 4 mm	2 x 0,5 mm (no polarity)
3AQUA-17	5 x 6 mm	3 x 4 mm	2 x 0,5 mm (no polarity)
3AQUA-19			

*The power to the indoor unit can proceed directly network or coming from the outdoor unit.

MODELs 3AQUA-11/14

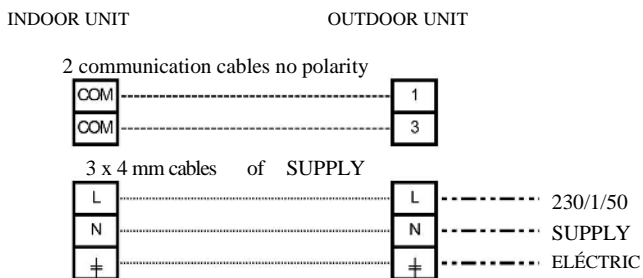

MODELs 3AQUA-17/19

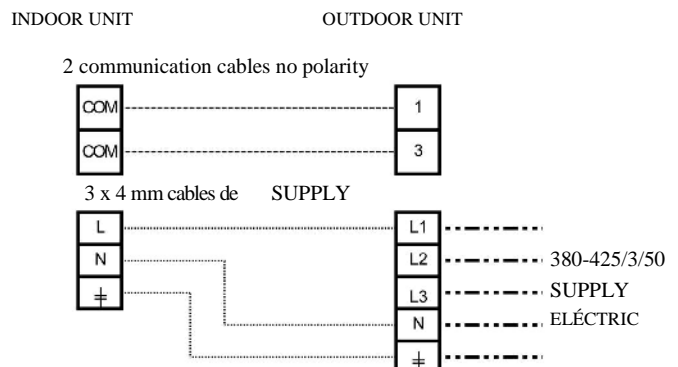

9. INSTALLATION

Electrical connection of the air conditioning water pump

INDOOR UNIT

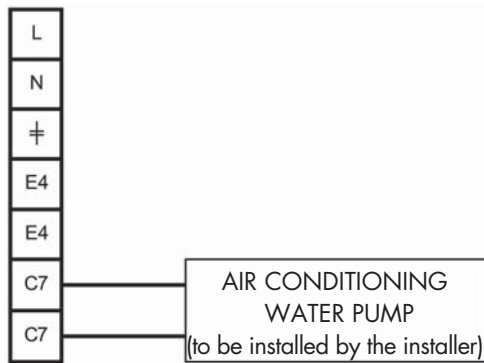

NOTE:

The air conditioning water pump must be installed externally, and the electrical connection is as indicated in this schematic and in Figure 10.

* Switch between single phase and 3 phase by setting dip switch on outdoor control board

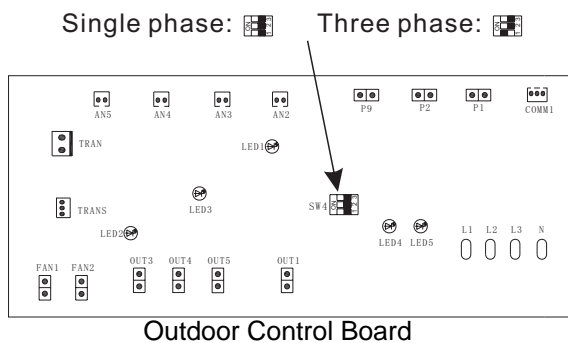

* Other dip switch meaning of SW4

SW4-2 off means for TriAqua heat pump
SW4-2 on means for Monobloc heat pump

SW4-3 off means for air source heat pump
SW4-3 on means for Water source/Geothermal heat pump

VERY IMPORTANT! PROTECTION AGAINST INDIRECT CONTACTS.

The installer must protect the unit's electric power supply line using automatic disconnection devices, a circuit breaker and a residual-current device that are suitable for the installation and in accordance with legislation in force.

Because the unit incorporates an electric heater, it must be kept in mind when sizing the power supply line of the indoor unit.

The unit's power supply cables cannot be lighter than ordinary, flexible polychloroprene sheathed cable (H05 RN-F designation).

Starting up the unit using an incorrect voltage line is not covered by the TriAqua warranty. Pay special attention to connecting the earth protection cable. It should be the first cable connected, and its length must be greater than that of the live cables.

9. INSTALLATION

9.5 REFRIGERANT CONNECTIONS

General considerations

The refrigerant lines will be interconnected as follows:

- The indoor unit has the gas and liquid intakes identified with stickers as follows:
Gas line: Gas (refrigerante)/Gas (refrigerant)
Liquid line: Líquido (refrigerante)/Liquid (refrigerant)
- All the refrigerant connections, just like the water connections, are threaded.
- The lines have to be insulated to prevent condensation and thermal losses.
- Once the lines have been installed, apply a vacuum to the refrigerant circuit of the indoor unit until a pressure of -1 Kg/cm^2 is reached for at least 2 hours.
- The refrigerant circuit can be emptied and the refrigerant can be charged through the service valves located on the right side of the outdoor unit.
- Check that there are no leaks on the refrigerant circuit.



Connection between units

On the indoor unit:

The indoor unit is equipped with couplings for screwing on the connections. Take the lines to the outlet zone of the connections on the indoor unit (see the schematic in section 6. Dimensions), and make the connections there.

The indoor unit leaves the factory with a dry nitrogen charge. The refrigerant lines of the indoor units are factory-fitted with adapters and nuts to guarantee a perfect seal until use.

On the outdoor unit:

The outdoor unit leaves the factory with a charge of R-410A refrigerant that is valid for a line length equivalent to a maximum of 5 metres. For lengths greater than 5 metres, a charge must be added according to the table in section 9.7.



Gas valve and liquid valve coupling

9. INSTALLATION

9.6 APPLYING THE VACUUM TO THE REFRIGERANT INSTALLATION

After making the refrigerant connection between the indoor and outdoor units, and after having checked the seal of the connection, a vacuum is then applied to the unit, for which the process below will be followed:

- With the service valves of the outdoor unit closed (as the unit is delivered from the factory), remove the caps from said service valves.
- Connect the pressure gauge manifold as follows:
 - The bottom intake of the pressure gauge manifold to the gas service valve.
 - The top intake of the pressure gauge manifold to the liquid service valve.
 - The central intake of the pressure gauge manifold to the vacuum pump.
- Start the pump and open the valves on the pressure gauge manifold to ensure depressurisation of the refrigerant circuit on both refrigerant lines and to the indoor unit.
- Apply vacuum until it is assured that the pressure gauge on the manifold indicates -1 bar.
- After applying the vacuum, close the valves of the pressure gauge manifold, and turn off the vacuum pump, and assure that the vacuum pressure is maintained for at least 15 minutes.
- If the pressure does not remain stable, it means that there is a leak in the circuit, which will have to be located and fixed. After fixing it, repeat the preceding steps.
- If the vacuum pressure remains stable (refrigerant could now be charged, if it were necessary), disconnect the intake from the pressure gauge manifold of the first vacuum pump, and keep the pressure gauge manifold closed, with the ends connected to the service valves or to the lines, as applicable according to each model.
- The outdoor unit leaves the factory with a charge of R-410A refrigerant that is valid for a line length equivalent to a maximum of 5 metres.
- Open the service valves.
- For line lengths of greater than 5 metres, re-charge the unit according to the refrigerant re-charge table.

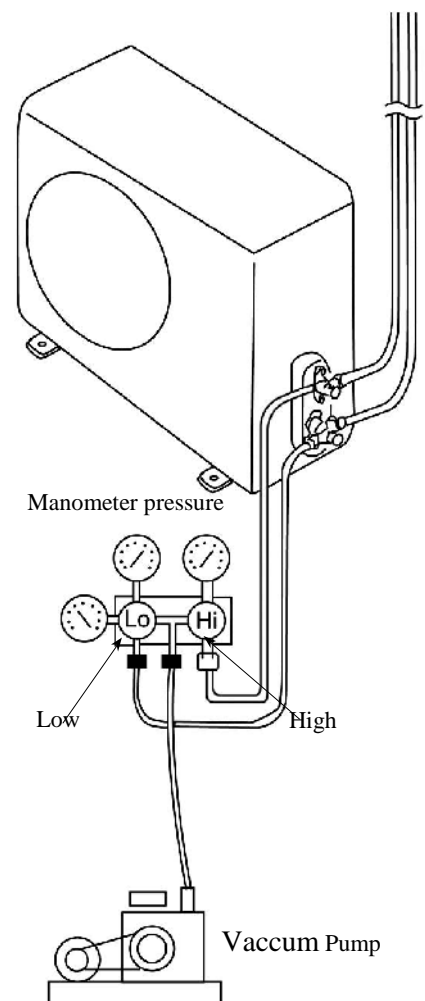

NOTE:

- To recover the entire refrigerant charge in the outdoor unit, close the liquid valve. The pressure is reduced to 0 Pa. Afterwards, close the gas valve.

9. INSTALLATION

9.7 RE-CHARGING REFRIGERANT (R-410A)

The outdoor unit includes the necessary refrigerant charge (R410A) for correct operation of the unit, up to an interconnecting tube length of 5 metres.

If the interconnecting tube is longer than 5 metres, it will be necessary to add refrigerant according to the following table:

Additional refrigerant charge (g / m)

DIAMETER	3/8"	5/8"	3/4"	Total
LÍQUID	60	-	-	-
GAS	-	8	10	-
3AQUA-11/12				68g
3AQUA-14/15/17/19/23	-			70g

NOTE:

- Introduce the refrigerant charge in the liquid phase.

9.8 PRESSURE MEASUREMENT. SITUATION

Outdoor Unit

There are two pressure taps (intake and compressor discharge) on the outdoor unit, whereby the evaporation and condensation pressure of the system can be measured, in any of the system's three functions (D.H.W., Heating or Cooling).

Indoor Unit

The indoor unit includes two pressure taps, which in the D.H.W. mode and heating mode will measure high pressure and in the cooling mode will measure low pressure.

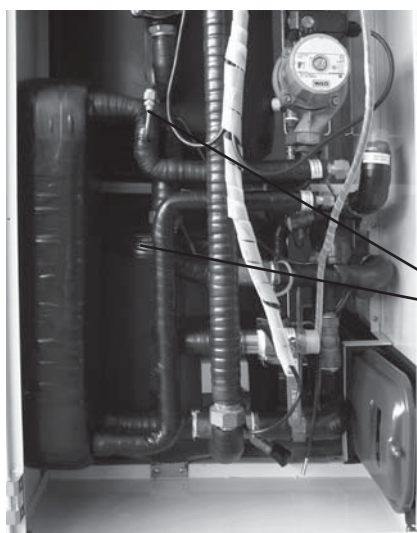

High or low pressure, depending on the operating mode



10. START-UP

10.1 CHECKS PRIOR TO START-UP

- Confirm that the electric power supply is in accordance with the specifications plate of the unit and that the connection has been made in accordance with legislation in force.
- Be sure that all the electrical connections are made perfectly and according to the electrical schematic.
- Check that the air conditioning water filter is clean.
- Check that the air conditioning buffer tank and DHW accumulation tanks are full of water and that the corresponding air bleed has been performed through the manual bleed valves.
- Check the rated pressure of the fill unit. This pressure must ALWAYS be below 2.5 bar. - Check that all the enclosure panels are correctly installed with their corresponding screws.
- Check that the corresponding portion of glycol (approximately 20% of the installation's total volume) has been introduced into the air conditioning circuit.
- Check that all the valves of the air conditioning hydraulic circuit (the secondary circuit also) are open.
- The operation and use of the electronic control is explained in Chapter 12. Electronic Controller.

10.2 VERIFICATION OF THE ELECTRIC POWER SUPPLY

After setting up the electric installation according to the installation manual and making the corresponding electrical connection, make the following checks:

- Check the strength of the fastening of the power supply and control cables, on both the indoor and outdoor units.
- Activate the differential switch and the circuit breaker of the unit.
- Check that the voltage of the outdoor unit is within the range indicated in the table of section 4 (electrical data). If it were outside that range, the unit must not be turned on.

10.3 TEMPERATURE SELECTION

- The unit is operated through the multiprocessor electronic controller.
- To turn the unit on, press the Run/Stop button for 1 second.
- The following operating modes can be selected:
 - Domestic hot water. The unit only produces DHW.
 - Domestic hot water and cooling. The priority is to satisfy the DHW demand. When this demand is satisfied, it continues to produce cold water for cooling.
 - Domestic hot water and heating. The priority is to satisfy the DHW demand. When this demand is satisfied, it continues to produce hot water for heating.
- Temperature modification.
 - The unit leaves the factory with set-point temperatures selected by default.
 - Modify and adapt these temperatures to the secondary installation that you have: radiating floor, fan-coil, etc.
 - Under extreme weather conditions, it may be advisable to modify these set-point temperatures.

10. START-UP

10.4 OPERATION IN D.H.W. MODE

- Enable operation of the unit in DHW mode, as indicated in section 12 of this manual.
- After having enabled the operating mode, the unit will start to operate until the selected set-point temperature is reached. Once said set-point temperature is reached, the unit will stop.
- Check the rotation of the DHW pump.
- The first time the unit is turned on, DHW should not be consumed in the home until the selected accumulation temperature is reached.

10.5 OPERATION IN AIR CONDITIONING MODE

- Enable operation of the unit in the Heating or Cooling mode, as indicated in section 12 of this manual.
- After the selected mode is enabled, and as long as the unit is not operating in DHW mode, the unit will start to operate and will send hot or cold water (depending on the heating or cooling mode) from the air conditioning circuit to the secondary circuit until the selected set-point temperature is reached.
- Once said temperature is reached, the unit will stop, but the air conditioning water pump will continue to operate.
- While operating in the heating and cooling mode, check the thermal difference in the water. (Impulse temp. - Return temp.). This difference should be around 5° C.

11. CONTROL PANEL

The unit's control panel is located at the top of the same:



11.1. Pressure indicator

The pressure indicator shows the water pressure on the air conditioning circuit, which should always be between 50 and 250 kPa (0.5 and 2.5 bar).

If the pressure is outside of these limits, call the maintenance service.

11.2. Electronic controller

The unit is operated through a multiprocessor electronic controller.

The user interface consists of a display, which shows information on the unit's status, and the 6 keys for selecting the operating mode, the desired set-point temperature, the programming, etc.

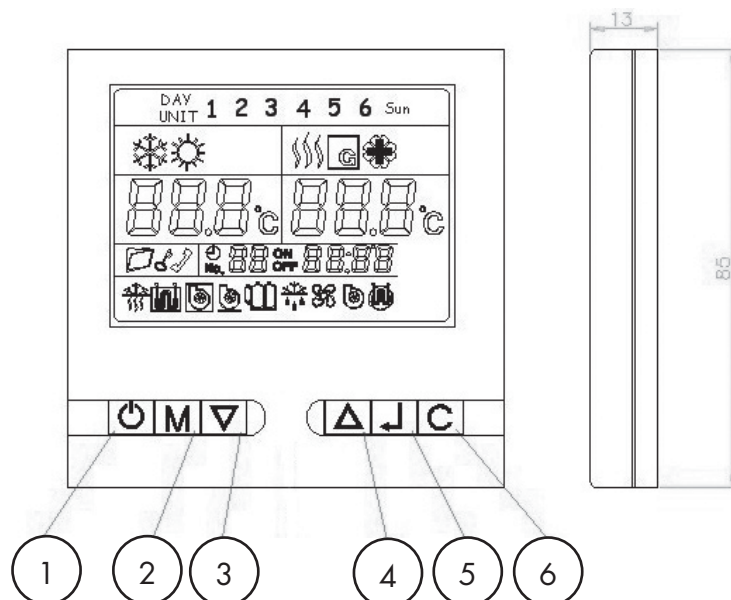

1. Run/Stop (⏻)
2. Operating mode selector (M)
3. Arrow down (▼)
4. Arrow up (▲)
5. Enter Confirmation (↵)
6. Clear. Delete (C)

11. CONTROL PANEL

11.3. Display

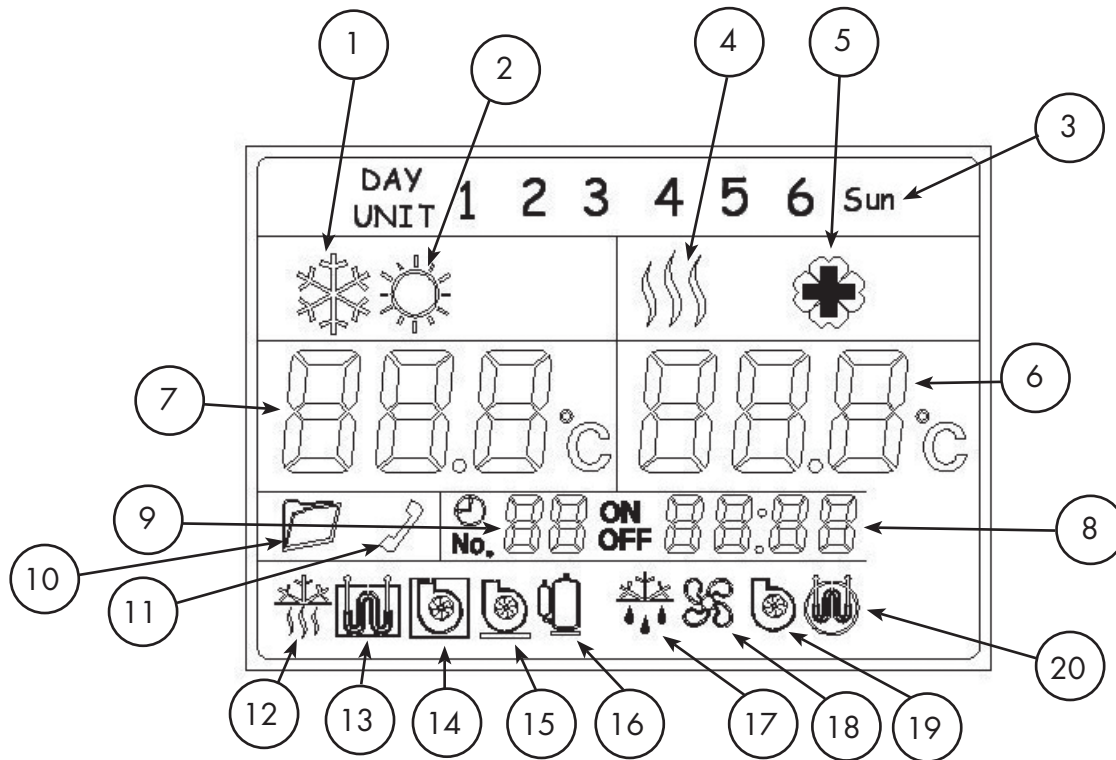

The following information can be viewed on the display:

1. Cooling operating mode.
2. Heating operating mode.
3. Day of the week.
4. DHW operating mode.
5. Anti-legionella.
6. DHW temperature.
7. Air conditioning temperature (Cooling or Heating).
8. Clock.
9. Timer.
10. Programming display.
11. Remote telephone control (not available).
12. Anti-freeze.
13. Air conditioning circuit heater (not available).
14. Water pump C7.
15. A/C water pump C8.
16. Compressor.
17. Defrost.
18. Exterior fan.
19. Water pump C5.
20. DHW heater.

12. OPERATING THE UNIT



12.1. Starting and stopping the unit

To turn the unit on, press the Run/Stop button  for 1 second.

To turn the unit off, press the Run/Stop button again  for 1 second.

12.2. Selecting the operating mode



The following operating modes can be selected by pressing the  button:

- Domestic hot water . The unit only produces DHW.
- Domestic hot water and cooling . The priority is to satisfy the DHW demand. When this demand is satisfied, it continues to produce cold water for cooling.
- Domestic hot water and heating . The priority is to satisfy the DHW demand. When this demand is satisfied, it continues to produce hot water for heating.

When the unit is started up, by pressing the run/stop button , the operating mode that it recovers is the last one that the unit was in.

12.3. Signaling of the operating mode

The following table shows the icons that appear on the Display according to the selected operating mode:

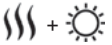
OPERATING MODE	ICON
D.H.W.	
D.H.W. + Cooling	
D.H.W. + Heating	

The  symbol appears on the Display when the DHW electric heater is automatically connected to prevent the formation of legionella.

12. OPERATING THE UNIT

12.4. Display and modification of temperatures

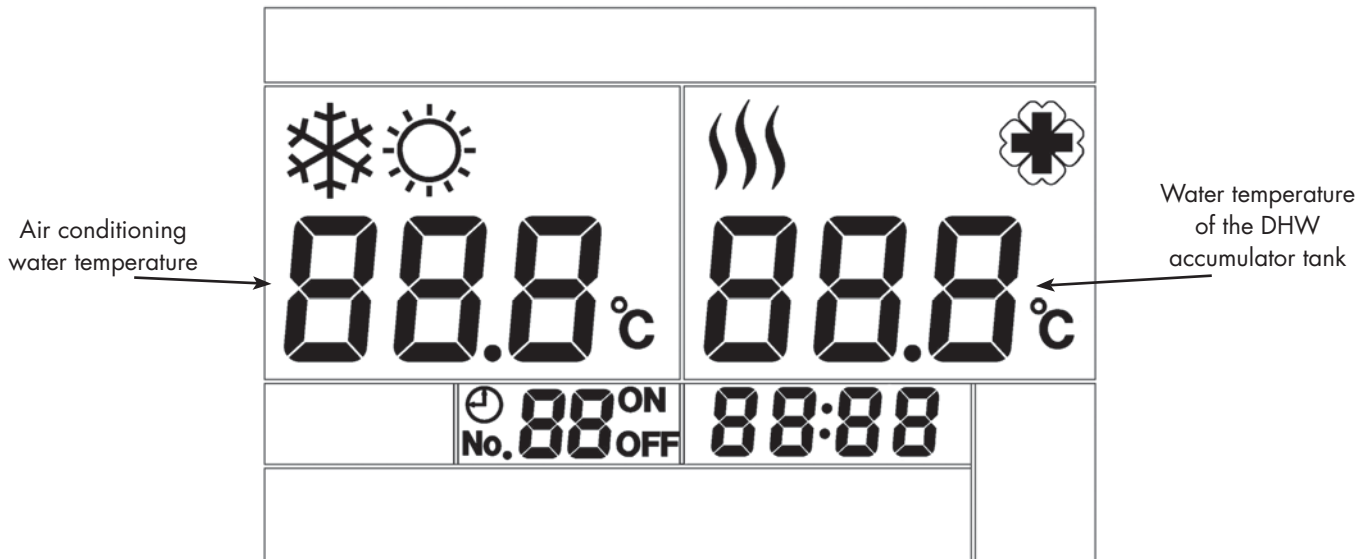

The air conditioning temperature (Cooling or Heating) appears on the left-hand side of the Display.

The temperature of the water in the DHW accumulator tank appears on the right-hand side of the Display.

The unit leaves the factory with set-point temperatures selected by default. These temperatures are ideal for correct operation under normal conditions. Under extreme weather conditions, it may be advisable to modify these set-point temperatures. It is advisable that these temperatures be modified only after having previously consulted your installer/maintenance service.

The set-point temperatures can be modified within the range shown in the following table:

TEMPERATURE	MINIMUM	MAXIMUM	BY DEFAULT
D.H.W. (Accumulator)	10° C	50° C	45° C
Heating (Return temp.)	10° C	50° C	40° C
Cooling (Return temp.)	10° C	25° C	12° C
Anti-legionella	60° C	70° C	65° C

To change the set-point temperature of the air conditioning return (either for heating or cooling), for DHW accumulation or for anti-legionella:

- Press **(M)** and **(C)** simultaneously for 3 seconds until the digits on the left-hand side of the display blink (heating/cooling temperature).
- Press the **(M)** key to select the operating mode. ❄️ Cooling or ☀️ Heating, DHW and anti-legionella.
- Use the **▲** and **▼** keys to select the desired temperature.
- Press the **(↵)** key to confirm the selected temperature.
- Press the **(C)** key to exit the programming table.

12. OPERATING THE UNIT

12.4.1 Programming of the anti-legionella function (anti-bacteria function)

- Simultaneously press **(M)** and **(C)** for 3 seconds. You will enter the temperature selection mode of the programmer.
- Press **(M)** until the anti-legionella function is reached.
- Use the **▲** or **▼** keys to select the desired heater temperature for said function (from 60° to 70° C).
- Press the **(↵)** key to confirm.
- The number of days appears blinking (7 days appear by default).
- Use the **▲** or **▼** keys to select the number of days for the interval between one anti-legionella process and the next one (values between 7 days and 99 days).
- Press the **(↵)** key to confirm. The word ON is displayed, and the hour digits blink on the clock.
- Use the **▲** and **▼** keys to select the start time.
- Press the **(↵)** key to confirm. ON disappears, and OFF is illuminated. The minutes digits blink on the clock.
- Use the **▲** or **▼** keys to select the minutes of duration of the cycle (values between 10 and 99 minutes). This time will start to run once the selected temperature has been reached in the accumulation tank.
- Press the **(↵)** key to confirm.
- Press **(C)** to finalise. If it were pressed before finalising the process, the previously pre-determined parameters would remain set.

ANTI-LEGIONELLA FUNCTION HEATER			
FUNCTION	MINIMUM	MAXIMUM	BY DEFAULT
DHW accumulation temp.	60° C	70° C	65° C
Temperature differential	1° C	3° C	2° C
Cycle duration time	10 minutes	99 minutes	10 minutes
Time between cycles	7 days	99 days	7 days

12.5. Clock and timer

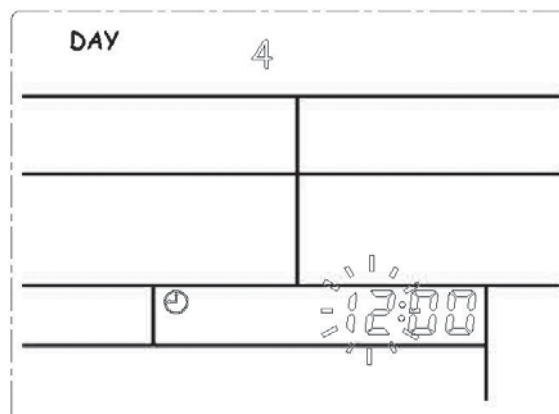

12. OPERATING THE UNIT

To adjust the clock time, the process below must be followed:

- Press the **(M)** key for 6 seconds. The digit of the day of the week starts to blink. For example "4" (Thursday).
- Press the **▲** or **▼** keys to select the day (between 1 – Sun).
- Press the **(↵)** key to confirm. The hour digits then start to blink.
- Press the **▲** or **▼** keys to select the hour (between 0 and 23).
- Press the **(↵)** key to confirm. The minutes digits then start to blink.
- Press the **▲** or **▼** keys to select the minutes (between 0 and 59).
- Press the **(↵)** key to confirm.
- Press the **(C)** key to exit the time programming process during any step.
- If **(C)** is pressed before having finished, the clock will remain with the time that it had initially.

The controller has a timer for programming the start and stop of the unit.

Three ON points can be programmed (1, 3 and 5) and another three OFF points (2, 4 and 6) for each day of the week. The unit can be programmed differently for each day of the week.

There are two types of timer programming, "S" and "C". In the "S" type, the programming is valid only for the week in progress. In the "C" type, the programming is repeated every week. See the following figure.



- Simultaneously press the **(M)** and **▲** keys for 3 seconds to enter the timer programming mode. "S" is displayed blinking (see the preceding figure). By pressing **▼**, you change from "S" to "C" programming and vice versa.
- Press the **(↵)** key to confirm the type of desired programming.
- After selecting the desired type of programming, the following screen is displayed:

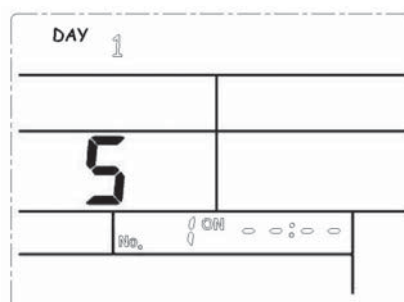

12. OPERATING THE UNIT

- To programme the first ON point, press the **(M)** key, and the hour digits will blink.
See the following figure.

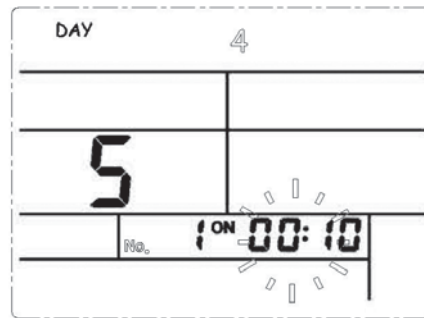

- Adjust the time of the ON point using the **▲** and **▼** keys. Whenever a key is pressed, the time increases or decreases 10 minutes.
- Press the **(↻)** key to confirm.
- When the first ON point is confirmed (point 1), the following screen is automatically displayed:

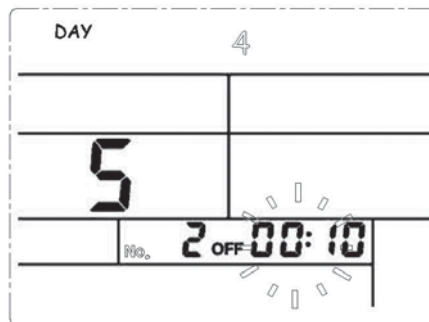

- The first OFF point is displayed (point 2), and the hour digits start to blink.
- Adjust the time using the **▲** and **▼** keys. Once the time is adjusted, press the **(↻)** key to confirm.
- When the first OFF point is confirmed (point 2), the screen with the second ON point is automatically displayed (point 3), and the hour digits start to blink.
- To programme the second and third ON points (points 3 and 5) and OFF points (points 4 and 6), proceed the same way as for programming the first point (points 1 and 2).
- After confirming the programming points of a day, the screen of the next day is automatically displayed blinking.
- Press the **(↻)** key to confirm.
- To programme the ON and OFF points of that day, proceed the same as for the preceding day. See the following figure.

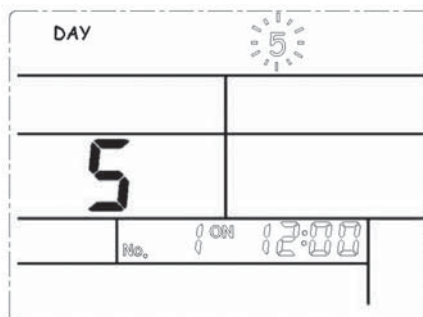

- If it is not necessary to programme a certain day, press **(C)** to skip the programming of the next day.
- To cancel all programming, press **(M)** and **▲** simultaneously for 3 seconds. Timer programming is entered, and then press **▲** and **(C)** simultaneously for 3 seconds. Timer programming will be cancelled.

13. ALARMS

In the event of any malfunction of the unit, the electronic controller will generate an error codes that are reflected in the table below, This code will replace the heating / cooling temperature part of the display on the left and the outdoor control board LED will flash red.

* The error code is displayed in the digits of the DHW temperature location.

* Error codes won't display directly. We must press once  to see the error code. Continue to press "Enter" key to see more error code if exist.

Error code	Error code meaning	Error display	Error Reason	Error Solution	LED1 blinks on outdoor control board
E9	Temp sensor of the of D.H.W water error	The compressor does not work in D.H.W. The heat pump will continue to produce D.H.W. with the heater element. Contact your support service	Sensor is broken or the connection is loose	Change or reconnect the sensor	8 flashes and 5 seconds off
E1	Sensor of water outlet from the heat exchanger of the air conditioning circuit error	The unit will continue to operate. The system uses sensor d5 instead of d3. Contact your support service about the problem.	Sensor is broken or the connection is loose.	Change or reconnect the sensor	7 flashes and 5 seconds off
P3	Sensor of water entering the heat exchanger of the air conditioning circuit error	The unit will continue to operate. The system uses sensor d3 instead of d5. Contact your support service	Sensor is broken or the connection is loose.	Change or reconnect the sensor	6 flashes and 5 seconds off
P1	Outdoor unit coil temperature sensor error	The compressor does not work in D.H.W. The unit will continue to produce D.H.W. with the electric heater. Contact your support service	Sensor is broken or the connection is loose.	Change or reconnect the sensor	14 flashes and 5 seconds off
P7	Outdoor air temperature sensor error	The compressor will stop for 20 minutes. It will then continue operating and will replace, sensor A4 by sensor A3. Contact your support, service about the problem.	Sensor is broken or the connection is loose.	Change or reconnect the sensor	5 flashes and 5 seconds off
PD	Not enough water flow, volume in the air conditioning circuit.	The unit will stop air conditioning mode if this anomaly occurs 3 successive times. When the water flow is resumed, the error should be cleared. If this does not occur, contact your support service.	Water flow switch connection loose or air conditioning water flow volume is too small. Or water filter is blocked by dirt -need to clean the filter as per page 18, figure 7.	1. If with water flow switch on the unit, please check if the connection is loose or the water flow switch is broken or the water pump is too small. 2. If without water flow switch on the unit, please check if the short connection wire is loose.	3 flashes and 5 seconds off
EN	Communication error between the indoor LCD control panel and the control board	The unit will stop operating. Contact your support service about the problem.	Communication wire is loose or control board is error.	Check the communication wires and control board. Reconnect the wires or change wires and control board	25 flashes and 5 seconds off
PA	Outdoor Electric connection missing phase protection	The unit will stop operating. Contact your support service	Power cable connection not Correct	Check the electric connection and reconnection the power cable.	1 flashes and 5 seconds off
PA	Outdoor Electric connection wrong phase.	The unit will stop operating. Contact your support service about the problem.	Power cable connection not correct	Check the electric connection and reconnection the power cable	1 flashes and 5 seconds off
E4	Pressure switch jump in high pressure	The compressor will stop. The unit will operate again when normal conditions are re-established. If this does not start, contact your support service	1. Vacuum is not good enough for refrigerant circuit. 2. There is air get inside of air conditioning water circuit. 3. There is dirt in the air conditioning water circuit. 4. Water flow volume is too small, water pump is too small. 5. High pressure switch is loose or broken	1. Check the refrigerant pressure. 2. Clean and purge the air from the water circuit. 3. Clean the air conditioning water inlet filter (Item 26 in explosion drawing) and other filter in the water circuit. 4. Change a bigger water pump 5. Reconnect high pressure switch or change the switch.	9 flashes and 5 seconds off
E5	Communication error between the indoor and outdoor control board	The unit will continue to produce D.H.W. with the heater element and the water pump. Contact your support service.	Communication wire is loose or Control board is error.	Check the communication wires and control board. Reconnect the wires or change wires and control board	2 flashes and 5 seconds off
P9	Pressure switch jump in low pressure	The compressor will stop. The unit will operate again when normal conditions are re-established. If this does not start, contact your support service	1. Heat expansion valve need to be preheated 2. Low pressure switch is loose or broken 3. Refrigerant leak	1. Power off for minutes and power on again then turn on the unit. May repeat this 2 or 3 times to preheat the expansion valve. 2. Reconnect the low pressure switch or change it 3. Check the whole system to see if the refrigerant is leaked.	12 flashes and 5 seconds off
PB	Solar thermal sensor error	Valve control for solar system will stop	Sensor is broken or the connection is loose	Change or reconnect the sensor	4 flashes and 5 seconds off

13. ALARMS

PB	Antifreeze protection(d3 or d4 1 ° C)	Compressor stop	4 way valve or compressor contactor or compressor error	Check the 4 way valve, compressor contactor or compressor.	4 flashes and 5 seconds off
E5	Error in the EEPROM memory of inner control board	Unit continue working but without historical record	EEPROM chip loose or error	Check EEPROM on the indoor control board	2 flashes and 5 seconds off
P2	Discharge air temperature sensor error	Unit stop	Sensor is broken or the connection is loose	Change or reconnect the sensor	16 flashes and 5 seconds off
E2	Suction temperature sensor error	Unit stop	Sensor is broken or the connection is loose	Change or reconnect the sensor	15 flashes and 5 seconds off
E3	Compressor High temperature Protection (115 ° C air discharge)	Compressor stop to protect the unit, when the temp is lower, the unit will start again. If this error occur twice in 30 minutes, the unit will be locked	1. Refrigerant volume is low 2. Thermal expansion valve error 3. Water flow volume is too low	1. Check the refrigerant pressure and check if there is leakage. 2. Check the thermal expansion valve 3. Check the water flow volume and check if the water pump is small or has dust or other problem.	11 flashes and 5 seconds off

14. MAINTENANCE

Before starting any maintenance or cleaning operation on the unit, be sure that the main power switch is disconnected and that no current reaches the same.

Ordinary maintenance

This section is designed for the end user. It is very important for maintaining regular operation of the unit over time. Just a few operations, performed periodically, can prevent a necessary call to service personnel.

The necessary operations do not require specific technical knowledge, and in brief, they are simple checks of some of the unit's components.

- Cleaning of the outdoor tube bank: The tube bank must be in good condition to maximise the thermal exchange. It is therefore necessary to keep the surface free of the dust and dirt that may become deposited because of the fans.

- Use a brush to remove all foreign objects such as paper, leaves, etc., that may be on the surface of the tube bank..
- Clean the aluminium surface of the tube bank using a vacuum cleaner, for example.
- Check that no fins are damaged or bent.

- Control of the defrost water flow: When operating in winter, frost can appear on the exterior tube bank. It is necessary to check that the drain is not obstructed.

If drainage is bad, a layer of ice could form on the base because of cold temperatures, which would compromise the operation of the entire system.

14. MAINTENANCE

Periodic maintenance

It is advisable that periodic maintenance be performed by qualified personnel.
Certain checks to be made are detailed below:

DHW Circuit

- Check the rotation direction of the DHW pump, as well as the possible existence of air in said pump.
- Check that the condensation and evaporation pressures in this operating mode are correct at all times, depending on the DHW temperature and on the outside air temperature.
- Check the electrical consumption (amperes) of the unit under the operating conditions at that time.
- Check that the unit stops in this operating mode when it reaches the selected temperature.
- Check that when the DHW temperature drops to the selected temperature, the unit starts operating in this mode.

Air conditioning circuit

- Check the rotation direction of the air conditioning pump, as well as the possible existence of air in said pump.
- Check that the condensation and evaporation pressures in this operating mode are correct at all times, depending on the impulse temperature of the air conditioning water and on the outside air temperature.
- Check that the thermal difference in the air conditioning water is within the recommended margins. If it is not, check the following: water pump, air in the water circuit, dirt in the water circuit, etc.).
- Check the electrical consumption (amperes) of the unit under the operating conditions at that time.
- Check that the unit stops in this operating mode when it reaches the selected temperature.
- Check that when the DHW temperature drops to the selected temperature, the unit starts operating in this mode.
- Check that the air conditioning water filter is clean.

15. SOLAR SYSTEM CONNECTION

Application 1 (Standard)

Connected with dual coils solar system. Solar preheating can be used for D.H.W and room heating in the same time. Automatic solar assistant Fuzzy Logic control program built inside to save cost the mostly.

- Our heat pump inner system can compare the solar tank temp and room heating returned water temp. the returned water will go through solar tank if it can get extra heat from solar heating. If in cloudy day, the returned water may not go through solar tank to avoid heat loss.
- For summer cooling circuit, inner program will always shorten the 'cooling' circuit automatically as it no need heat.
- Domestic hot water will always go through solar tank to be preheated.

So the heat pump can have a good rest in sunny day to save cost and work more in cloudy day. Especially excellent for floor heating together with hot water application.

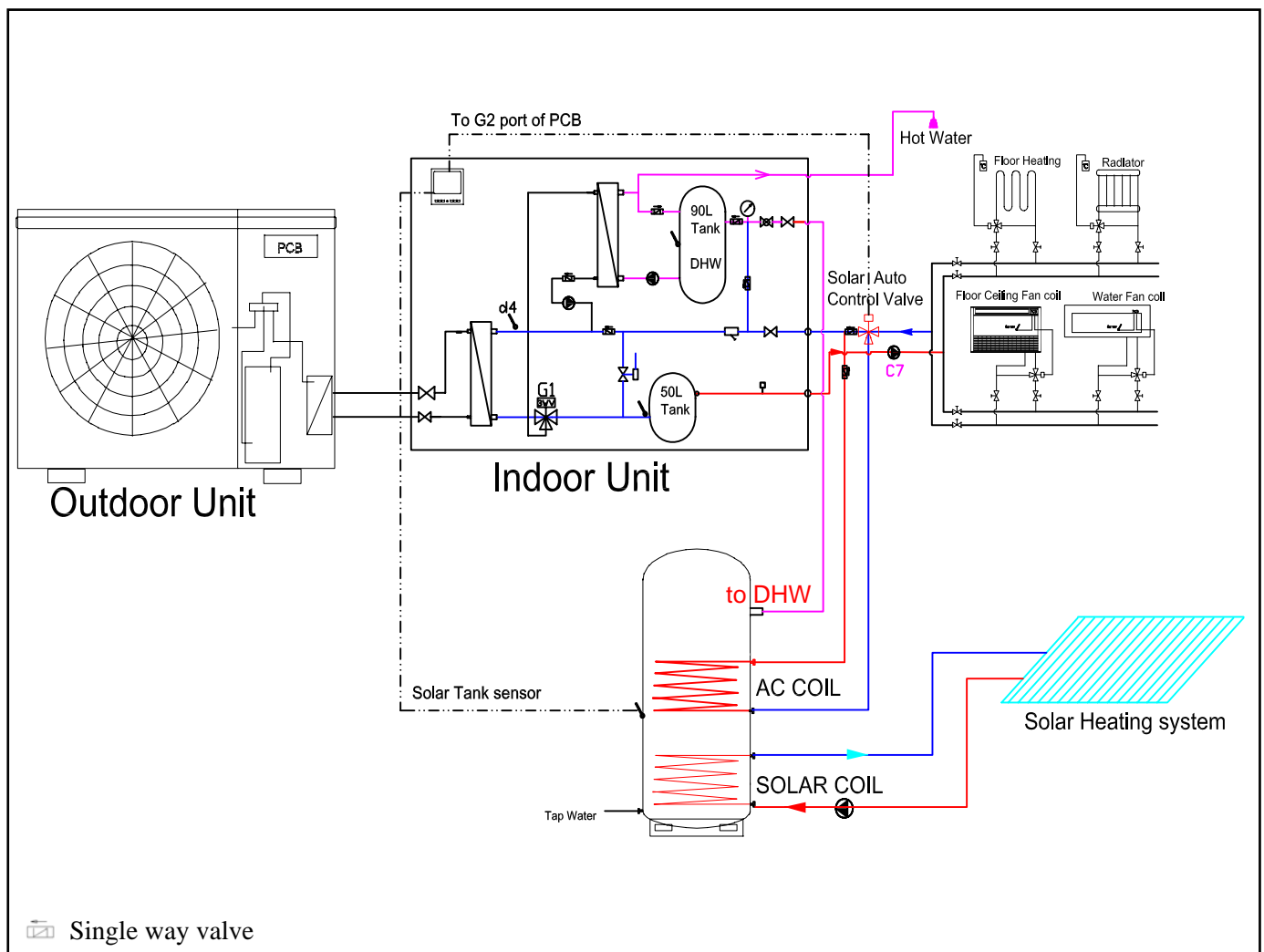

Note:

To make sure the above application working well, note the following procedure

1. Check the indoor wiring diagram in page38 for G2 port and solar water tank sensor location.
2. Solar automatic control 3 way valve(220V) need to be connected to G2 port of indoor PCB
3. Solar tank sensor from indoor PCB need to be put in the middle of the solar water tank and should be located above the solar coil as shown above diagram.
4. Solar system need to be connected with lower coil of water tank ; air conditioning water system need to be connected with upper coil of water tank.

15. SOLAR SYSTEM CONNECTION

Application 2 (optional- need special requirement for Triaqua inner DHW coil when placing order)

Solar panel or vacuum pipe is directly connected with Triaqua heat pump inner D.H.W water tank coils. The inner recycle fluid can be brine to avoid freeze in winter. It can save one solar water tank cost.

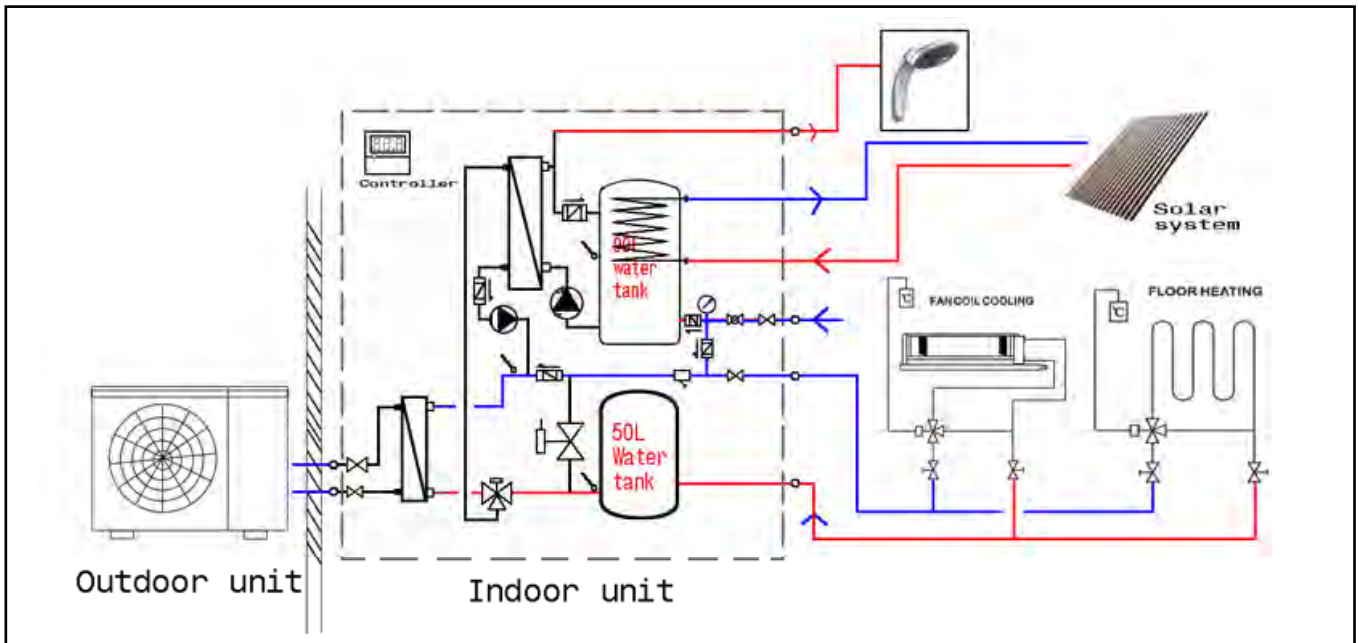

Application 3

Connected with normal mono type solar system with water tank together with solar vacuum pipes. Applicable for mild weather area.

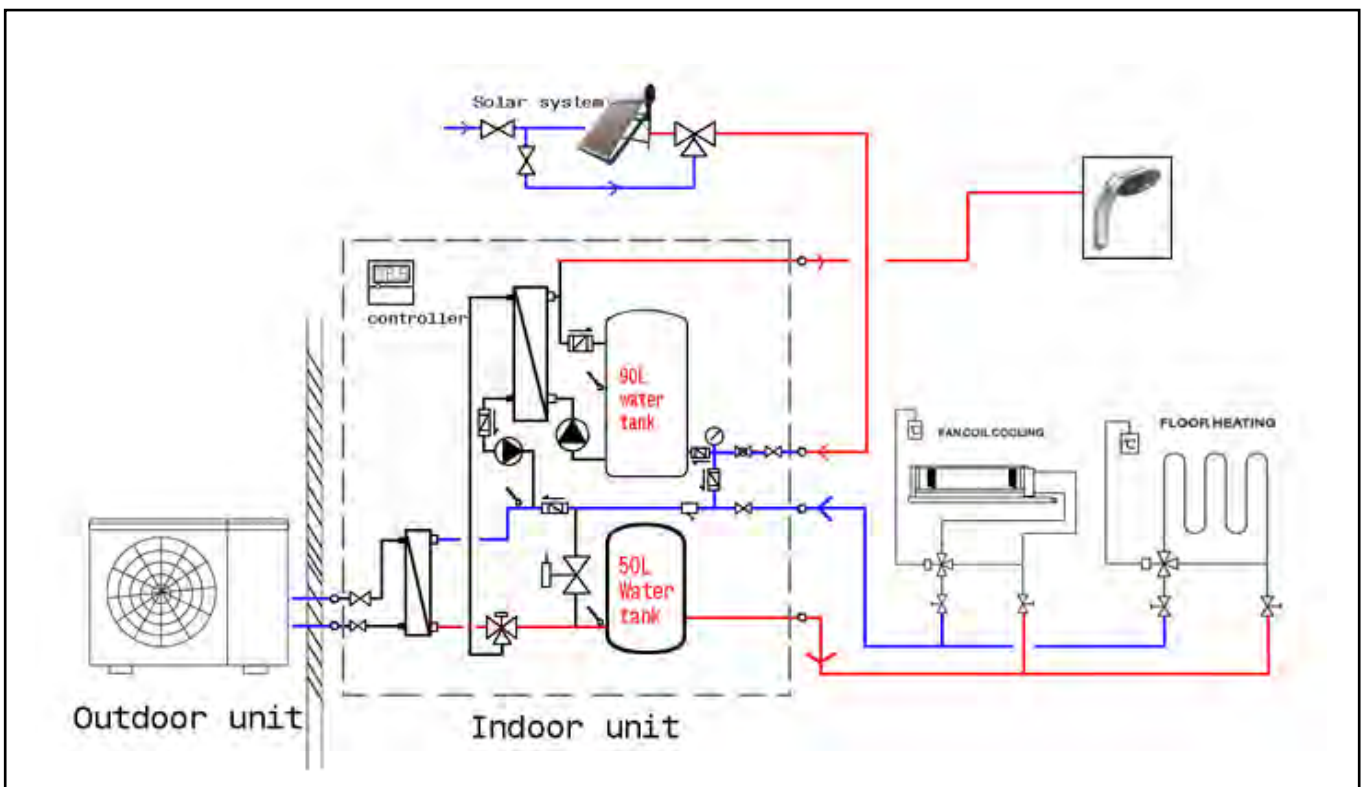

INDOOR UNIT (ALL MODEL)

ESQUEMA ELECTRICO UNIDAD INTERIOR (11KW/14KW/19KW)

INDOOR UNIT ELECTRIC DIAGRAM (11KW/14KW/19KW)

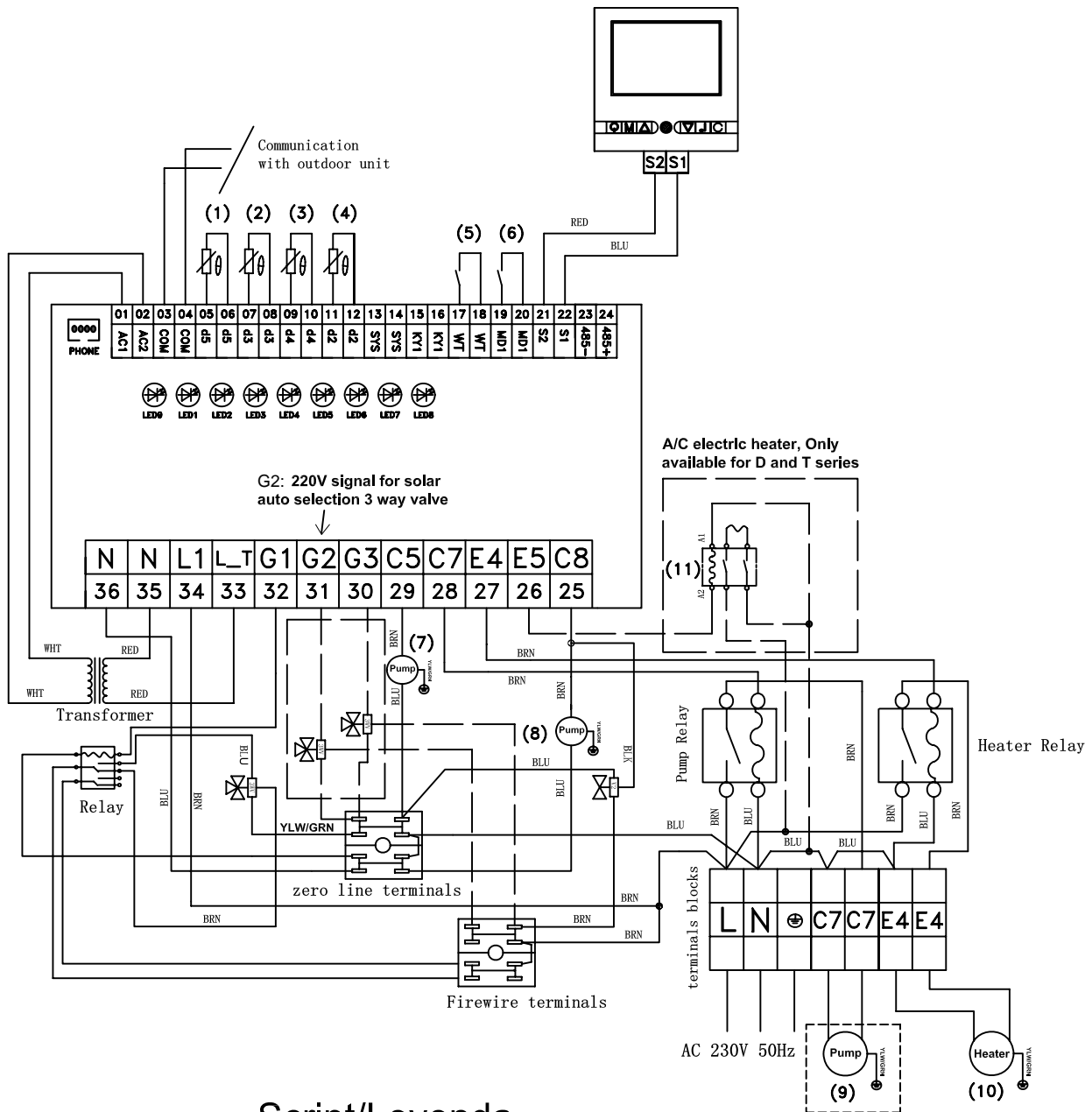

Script/Leyenda

1	Solar tank sensor	Sonda acumulador solar termica
2	A/C outlet water sensor	Sonda salida agua clima
3	A/C inlet water sensor	Sonda entrada agua clima
4	DHW tank sensor	Sonda temperatura ACS
5	Water flow Switch	Puente
6	Function switch	Interruptor de funcionamiento
7	DHW water pump	Bomba agua ACS
8	DHW water pump	Bomba agua ACS
9	A/C water pump(not included)	Bomba agua clima(no incluida)
10	DHW electric heater	Resistencia electrica ACS
11	A/C electric heater	Resistencia electrica AA

Wires/Cables

BLU	Blue	Azul
BLK	Black	Negro
ORG	Orange	Naranja
RED	Red	Rojo
BRN	Brown	Marron
GRN	Green	Verde
WHT	White	Blanco
YLW	Yellow	Amarillo
GRY	Grey	Gris

G2:For solar Fuzzy logic auto 3 way valve

G3:For seasonal auto switch 3 way valve

ESQUEMA ELECTRICO UNIDAD EXTERIOR 11K/14K OUTDOOR UNIT ELECTRIC DIAGRAM 11K/14K

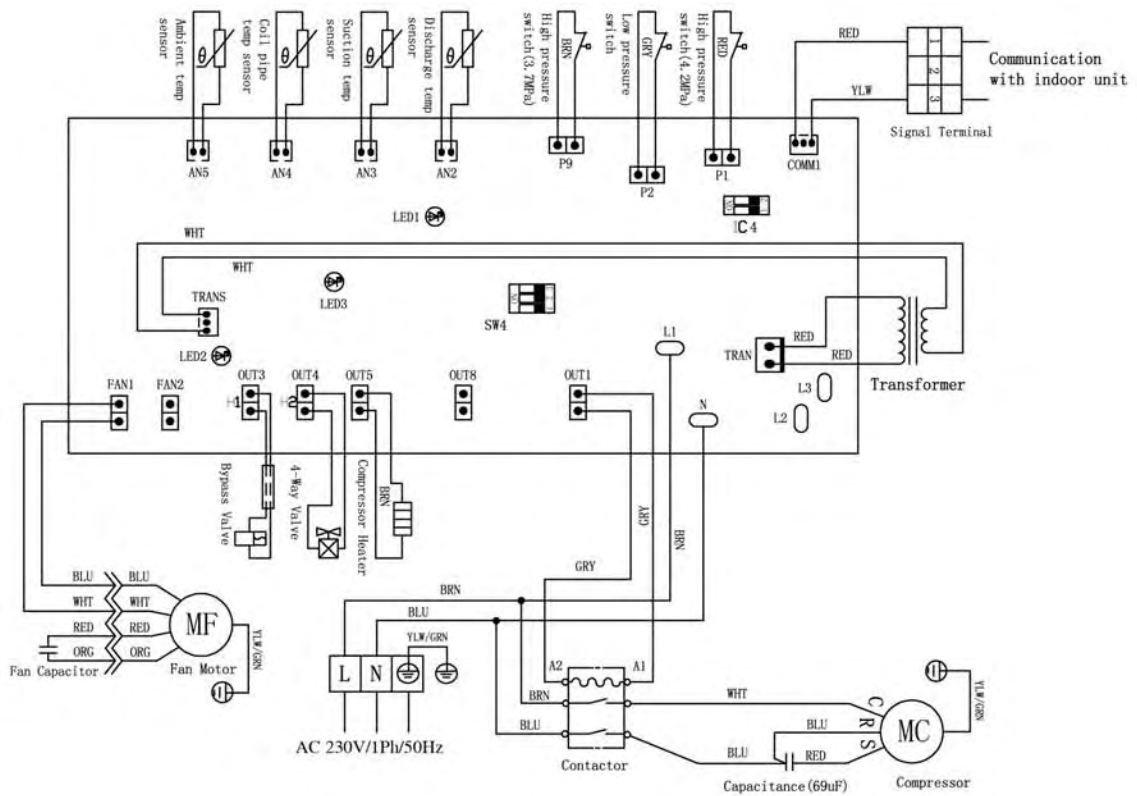

Script / Leyenda

Ambient temp sensor	Sonda temp aire exterior
Coil pipe temp sensor	Sonda desescarche
Suction temp sensor	Sonda aspiración
Discharge temp sensor	Sonda descarga
High pressure switch	Presostato alta
Low pressure switch	Presostato baja
Communication with indoor unit	Comunicacion con unidad interior
Signal terminal	Bornas de comunicación
Transformer	Transformador
Compressor heater	Resistencia carter compresor
4-Way valve	Valvula 4 vias
Bypass valve	Valvula de inyeccion
Fan capacitor	Condensador ventilador
Fan motor	Motor ventilador
Contactora	Contactora
Compressor	Compresor
Soft starter	Arrancador progresivo
Capacitance	Condensador ventilador
Resistance	Resistencia

Wires / Cables

BLU	Blue	Azul
BLK	Black	Negro
ORG	Orange	Naranja
RED	Red	Rojo
BRN	Brown	Marron
GRN	Green	Verde
WHT	White	Blanco
YLW	Yellow	Amarillo
GRY	Grey	Gris

ESQUEMA ELECTRICO UNIDAD EXTERIOR 17K/19K OUTDOOR UNIT ELECTRIC DIAGRAM 17K/19K 3PHASE

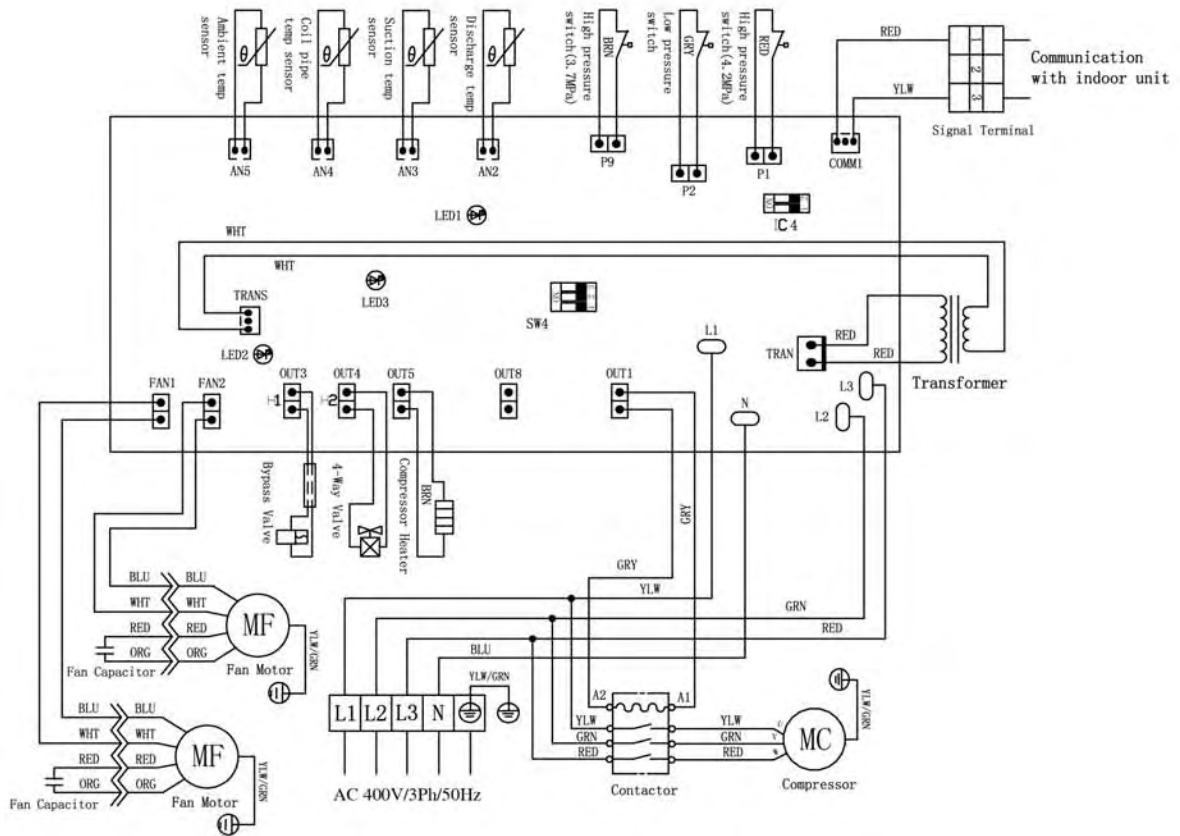

Script / Leyenda

Ambient temp sensor	Sonda temp aire exterior
Coil pipe temp sensor	Sonda desescarche
Suction temp sensor	Sonda aspiración
Discharge temp sensor	Sonda descarga
High pressure switch	Presostato alta
Low pressure switch	Presostato baja
Communication with indoor unit	Comunicacion con unidad interior
Signal terminal	Bornas de comunicación
Transformer	Transformador
Compressor heater	Resistencia carter compresor
4-Way valve	Valvula 4 vias
Bypass valve	Valvula de inyeccion
Fan capacitor	Condensador ventilador
Fan motor	Motor ventilador
Contactor	Contactor
Compressor	Compresor
Soft starter	Arrancador progresivo
Capacitance	Condensador ventilador
Resistance	Resistencia

Wires / Cables

BLU	Blue	Azul
BLK	Black	Negro
ORG	Orange	Naranja
RED	Red	Rojo
BRN	Brown	Marron
GRN	Green	Verde
WHT	White	Blanco
YLW	Yellow	Amarillo
GRY	Grey	Gris

Check List Before Turn On Triaqua Heat Pump

Better to print this page out and make sure that you can tick all of the following items to avoid any problem After finish the installation tasks, please check the items listed below before turn on Triaqua heat pump

Things you should have done:

1. Power cable

Check if the power cable is connected correctly, and check if the screws have been screwed down and tight. Please use specified cables.

Yes

2. Communication wire

Check if the communication wire is connected correctly, and check if the screws have been screwed down and tight. Please adopt specified communication wire.

Yes

3. Water circuit

-a. Check if the water pipes are correctly connected, and the pipe dimensions are correct.

Yes

-b. Check if all the shut off valve and manual valve is opened, check if all the joint is fastened.

Yes

-c. Check if air exhaust valves on the water terminals must be open for the 1st water recycle running to exhaust air in the terminals. This valve can be closed when this valve drain continuous water.

Yes

-d. Check if air exhaust valves for the whole water circuit is opened. An automatic purging device has to be installed at the highest point of the water circuit.

Yes

-e. Open the maintenance screw in the middle of the water pumps (for both DHW and air conditioning circuit) and manually rotate the water pump axis. This action should also be done when electric power disconnected for more than 24 hours to avoid block.

Yes

4. Be sure the two water tanks are full of water. If the water tanks are empty, the electric heaters inside is dangerous to be broken.

Yes

5. Insulation test of power supply circuit

Please inspect it by a ohmmeter of 500V

Apply the voltage of DC 500V between the power supply terminal block and the ground wire, test the insulation resistance. The insulation resistance must be more than 2 ohms.

Yes

Triaqua Heat Pump Test Run Procedure

Switch on the power supply

1. The power indicator(LED) will be lighted. The compressor heater will be started.

Yes

2. Turn on the heat pump and check if the heat pump is in air conditioning heating mode, if not, please press M button on the LED controller to change the operation mode to heating mode.

Yes

3. The circulation pump will start before the compressor. Make sure the water pump is working well.

Yes

4. The compressor will be started in 3 minute after powered on.

Yes

MOST IMPORTANT!

1. Make sure it is not in cooling mode during first operation or test running, until you make sure the air conditioning water pump is working properly and water circuit is recycling smoothly.

Recommand to test the water pump working condition and water circuit directly before switch on Triaqua heat pump.

2. Select a big enough water pump for the air conditioning water circuit.

3. Always keep the electricity connection with Triaqua heat pump to enable inner antifreeze function.

TriAqua!

□ I-MTI-0001-11

The manufacturer reserves the right to make any change without prior notice.